

# Towbar Wiring Harness Fitting Instructions



SKU

PRODUCT

**UNT300**

**DUAL-VOLTAGE SMART ECU WIRING KIT**

**ATTENTION!**  
Read Before Installation

**THIS UNIT IS DESIGNED FOR VEHICLES WITH DUAL VOLTAGE WIRING FOR BRAKE & TAILLIGHTS. The unit can also be used on other vehicles without this feature .**

**Please note:** This unit may require dealer coding. If your trailer has fog lights, reverse sensors or stability control features, this unit will not connect to them.

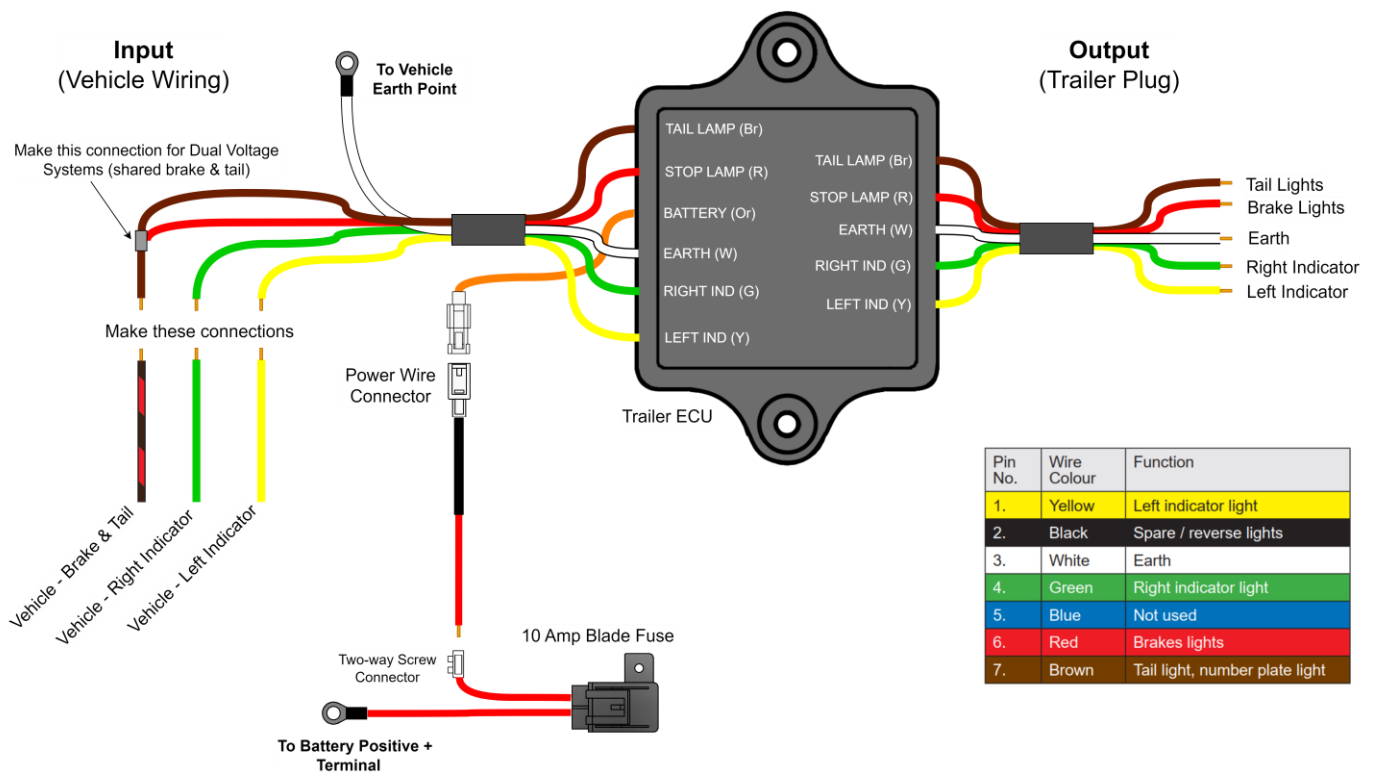

## Fitting Guide\*:

1. For vehicles with dual voltage wiring for combined brake & taillights, splice together the brake and tail wires from the ECU output.
2. Be sure to connect the ground/earth terminal wire correctly to a suitable location on the vehicle body.
3. The ECU must be mounted securely and away from heat sources. In addition to the supplied double-sided tape, it is recommended to use additional fasteners or cable ties (not included) to ensure the ECU is secure.
4. Ensure the wiring is routed away from sources of heat and sharp objects. Secure the cables at 200mm intervals with cable ties (not included).
5. Please inform the owner/ operator of the vehicle is aware of the location of the 10Amp blade fuse in the event the fuse needs to be replaced.

**\*The installation of this harness must be carried out by a qualified auto-electrician.**