

# Fitting Instructions



SKU

**T8P858**

PRODUCT

## **TAG Heavy Duty Towbar & Galvanised Step for Mercedes Benz Vito Van 447 Series (116 & 119 Variant) (03/2015 - On)**

SPECIFICATIONS

- Towbar Class: CL 4 Heavy Duty
- Towing Capacity: 2500kg
- Tow ball Weight: 250kg
- Approx. Fitment Time: 90 Minutes

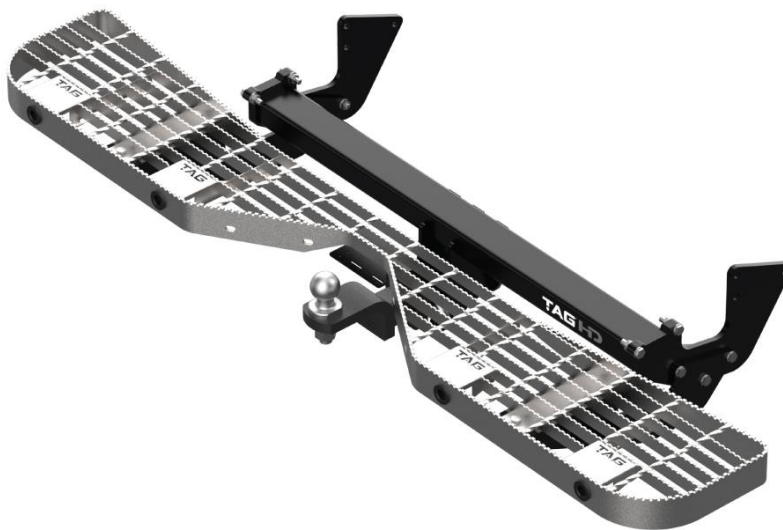

Scan for latest version of these instructions

TOOLS REQUIRED

- Spanners
- Sockets
- Air Saw or similar.
- Trim Removal Tool
- Torque Wrench

IN THIS GUIDE

- Fitment Instructions
- Torque Settings
- Warranty Info

# Towbar Assembly

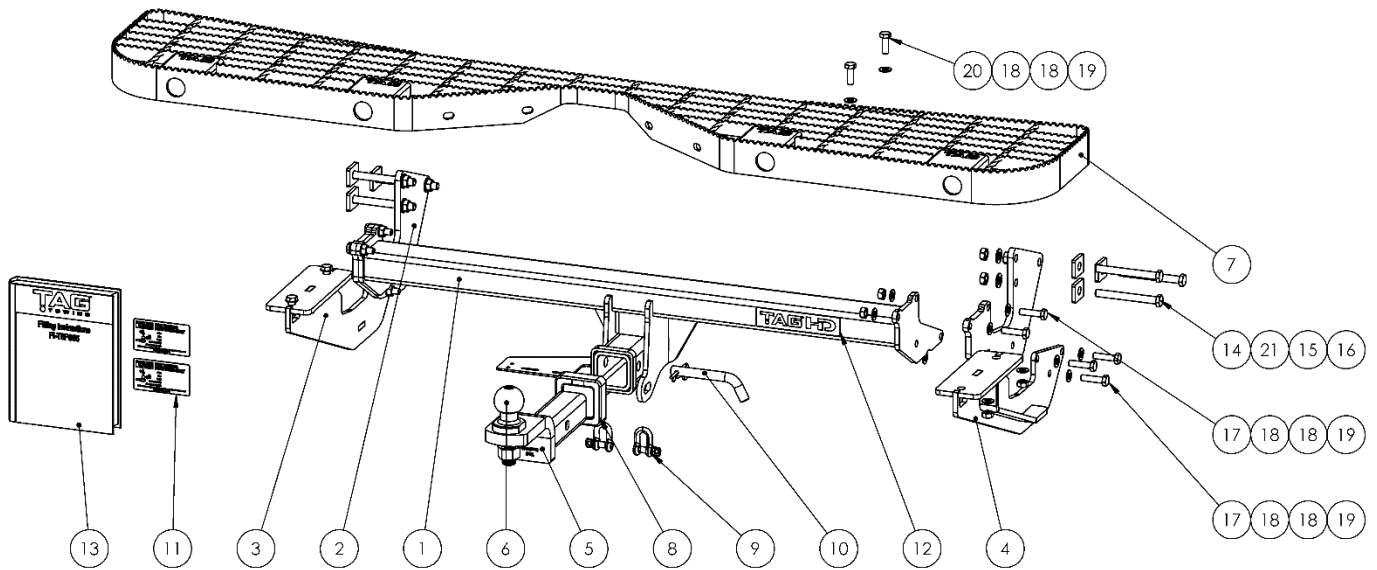

Item No.	Description	QTY.	Item No.	Description	QTY.
1	Welded Assembly	1	12	TAG HD Sticker	1
2	End Plate	2	13	Fitting Instruction	1
3	PS Step Mount Assembly	1	14	M12 x 1.25 x 110 Bolt	6
4	DS Step Mount Assembly	1	15	M12 Flat Washer Zinc	6
5	L4180 Ball Mount	1	16	M12x1.25 Nut	6
6	50mm TAG Chrome Towball	1	17	M10 X 40 x 1.25 Bolt	10
7	Tow Step - Galvanised Step Assembly	1	18	M10 Flat Washer	28
8	TAG Hitch Cover	1	19	M10 X 1.25 Nut	14
9	D-Shackle - 10mm. 1000kg	2	20	M10 X 30 x 1.25 Bolt	4
10	Class 4 Pin & Clip	1	21	Top Plate - 40x32x6	6
11	Compliance Label	3			

# Important Information



## Warning:

- This product is for towing purposes only and must only be loaded as shown in your vehicle Owner's Manual.
- This towbar is NOT to be drilled, cut, welded, or modified in any way.
- Check behind chassis rail and body panels before drilling to ensure no hazards are present.
- All load ratings shown are under the assumption your trailer has a functional braking system installed.
- When installed in positions other than the one depicted in these instructions the Tow Ball Mount may interfere or obstruct certain features of your vehicle (tailgate opening, Chassis clearance, etc.)

## General:

- Before fitting this towbar read fitting instructions and check installation hardware is correct.
- Check that the towbar is suitable for the vehicle and be wary of any changes to the vehicle design that may conflict with the fitting of this towbar. (Tray, Canopy, Suspension etc.)
- After drilling, blow any filings clear, remove any burrs and treat exposed metal with a rust inhibitor.
- The high tensile fasteners supplied with this product are an integral feature to achieving the specified rating, if replacement is required ensure that fasteners of the same grade (8.8) & quality are used. Contact an authorised TAG distributor or the TAG fitment center - (07) 3208 3022 - if further information is required.

## Towbar Maintenance and Care:

It is recommended, when not in use, that the Tow Ball Mount assembly and class 4 Pin and Clip is stored inside the car away from moisture to prevent standing water from forming rust. Inspect to ensure, on regular basis, fasteners are torqued to the specifications below and in good condition.

Ensure that the fitting instructions are read and understood prior to fitment, Following the fitment place these instructions in the vehicle's glovebox after installation is completed.

*Metric Bolt Torque Settings*

Diameter	Pitch	Grade	Torque	Unit		Diameter	Pitch	Grade	Torque	Unit
M8	1.25	8.8	29	Nm		M12	1.25	10.9	125	Nm
M10	1.25	8.8	57	Nm		M12	1.50	10.9	105	Nm
M10	1.50	8.8	44	Nm		M14	1.25	10.9	195	Nm
M12	1.25	8.8	101	Nm		M14	1.50	10.9	165	Nm
M12	1.50	8.8	97	Nm		M16	1.25	10.9	295	Nm
M12	1.75	8.8	77	Nm		M16	1.50	10.9	250	Nm
M14	2.00	8.8	122	Nm		50mm Tow Ball	N/A	N/A	300	Nm
M16	2.00	8.8	190	Nm		70mm Tow Ball	N/A	N/A	750	Nm

# Installation Instructions



## Step 1: Remove Rear Bumper

**Note to installer: Fitting of this step will inhibit the correct function of the reverse sensors. It is recommended that the provided RSM Kit be used to relocate the OEM reverse sensors onto the step & wiring extended.**

- a. Open rear doors or tailgate.
- b. Lower the spare wheel.
- c. Beneath the taillight, remove 2x Torx screws and 1x scrivet. Repeat on opposite side.
- d. Remove 4x Torx screws from along the top of the bumper. (Below rubber door seal).
- e. Remove 1x scrivet from inside the wheel arch and 1x scrivet behind on the bottom of the bumper. Repeat on opposite side.
- f. Remove 2x scrivets from the bottom rear edge of the bumper.
- g. Retain all fasteners.
- h. Beginning at each wheel arch, carefully separate the plastic bumper from the steel body.
- i. Remove and discard the shipping hook & fasteners from the chassis.
- j. Remove the plastic under tray, if fitted, via 2x plastic nuts.



## Step 2: Fit Towbar

- Align the holes of each endplate to those on the inside of the chassis and loosely secure with 3x M12x 1.25x 110 bolts with flat washers and nut. Repeat on the opposite side.
- Lift the welded assembly up to the endplates and loosely secure with 4x M10x 1.25x 40 bolts with flat washers and nuts. Repeat on the opposite side.
- Tighten all the M12** chassis bolts according to the torque specification. Page (3).
- ONLY Tighten the 2x upper-most M10 bolts on each side** according to the torque specification. Page (3).
- Leave the 2x lower-most M10 bolts loose on each side** as they will be used for the step mount after re-fitting the bumper.

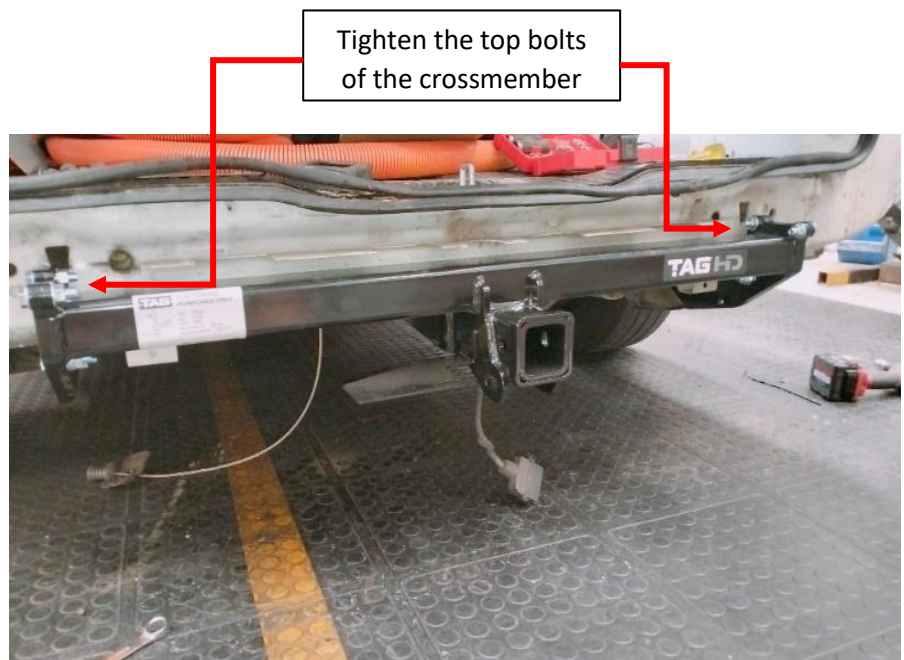

# Installation Instructions



## Step 3: Cut Bumper

**Note:** The towbar installer is ultimately responsible for the location & quality of the bumper cut. To avoid mistakes, please use the following measurements as a guide only. We suggest making small incremental cuts and regularly test fit the bumper to ensure an accurate and tidy appearance. The additional application of rubber pinch-weld around the cut edge ensures a neat & tidy look.

Please Note:

- Pre MY25 vehicles have a one-piece bumper. See below for dimensions.
  - MY25 onwards bumper has a detachable centre cover. Centre cover can be removed for ease of trimming. See below for dimensions.
  - Both models use the same dimensions for the step mount cuts of the bumper.
- a. Establish the centre of the bumper.
  - b. Cut the bumper using an air hacksaw or other suitable cutting device.
  - c. De-burr all cut edges.
  - d. Refit bumper in reverse of steps.

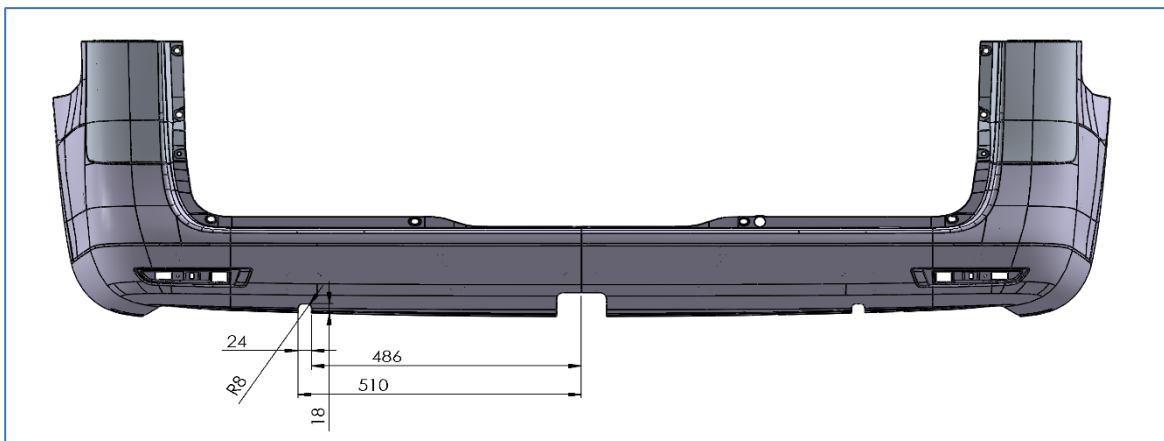
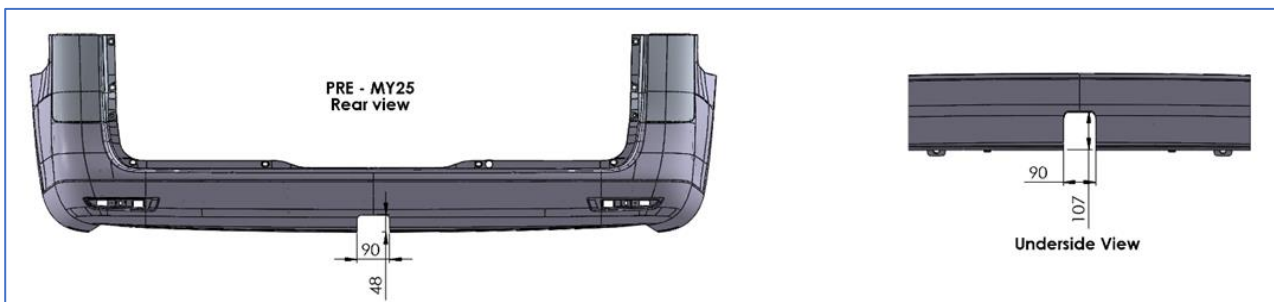
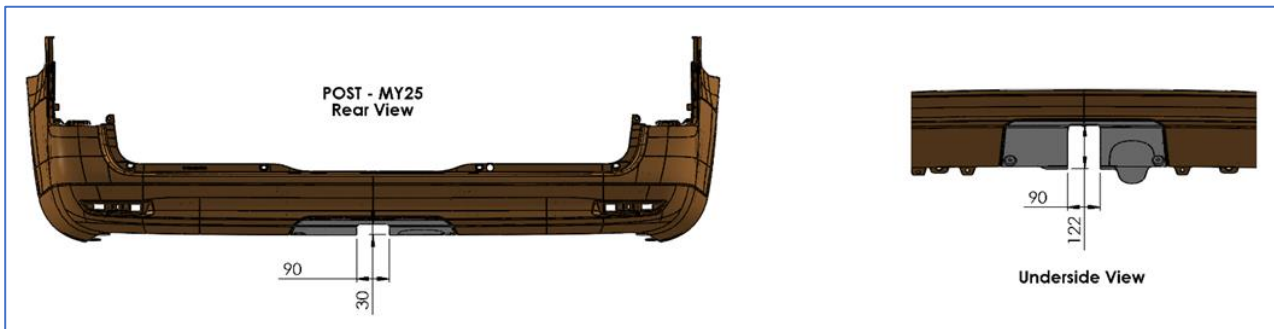



---

## Step 4: Fit Galvanised Step

---

- a. Remove the loose, lower-most M10 bolts from the towbar endplates installed in **Step 2**.
- b. Lift the step mounts up to the outside of the towbar endplates and align the holes. Re-insert the M10 bolts and washers and secure loosely with M10 nuts and washers.
- c. Insert the remaining M10x 1.25x 40 bolt in the centre hole and secure loosely with M10 nuts and washers.
- d. Lift the step onto the mounts and loosely secure with 4x M10x 1.25x 30 bolts, washers and nuts.
- e. Align the step with the bumper and tighten all bolts according to the torque specification on page 3.

# Installation Instructions



## Step 5: Complete Towbar & Apply Spare Compliance Label

- Attach TAG Hitch cover with rubber mallet carefully to prevent breaking.
- Attach the tow ball to the ball mount. The flat side of the tow ball **MUST BE** parallel to the outer edge of the ball mount. **Tighten the tow ball to 300Nm.**
- Insert the ball mount into the receiver and secure with the Pull pin and R-Clip. When not in use, secure the Ball Mount in a safe place inside your vehicle.
- Apply one of the compliance labels to the pillar of the driver's door. Place the remaining label and the fitting instructions in the vehicle handbook.

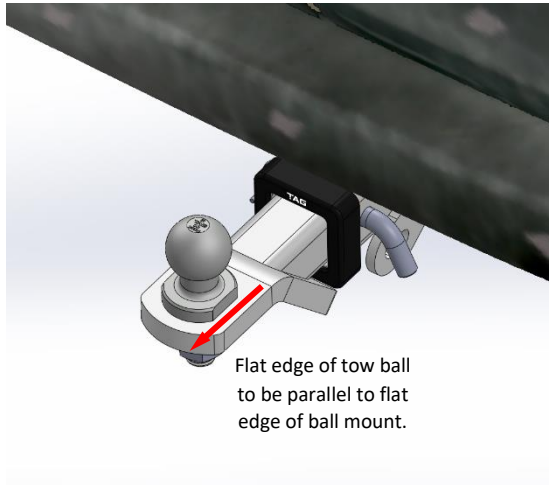

# TAG Warranty Statement



SWD warrants your TAG Towbar for its full product life under the following conditions:

- You can show proof of purchase.
- The towbar has been correctly installed by a suitably qualified installer.
- The towbar has not been modified or abused in any way and has only been used for the purpose intended.
- The towbar was not fitted second hand to your vehicle.

The extent of this warranty includes materials and workmanship used in the manufacture of the towbar and is to the equivalent value of current, full replacement cost.

Nothing stated or implied in this warranty limits in any way, the statutory rights that you may have.

To make a claim visit the original installer in the first instance or, if you are unable to or are not satisfied with their help, then contact us direct by phone on 1300 669122 or visit [www.swd.com.au](http://www.swd.com.au).