

TRAILBOSS

Towbar Fitting Instructions To Suit PEUGEOT 508 MY12 ON Part Number QTPG2L Rating 1900/75 kg

PLACE THESE INSTRUCTIONS IN THE VEHICLE'S GLOVEBOX AFTER INSTALLATION IS COMPLETE

WARNING:

1. Do not, drill, cut, weld or otherwise modify the tow bar.
2. If you are using electric welding on a motor vehicle, **always** check that the vehicle is not equipped with electronic engine or instrument management equipment. Failure to do so could **destroy** any onboard computers. If in doubt, check with the vehicle's manufacturer.
3. The high tensile fasteners supplied with this product were used to achieve the specified rating. If replacement is required ensure that fasteners of the same rating & quality are used. Contact an authorised **Trailboss** dealer if further information is required.

General:

1. Ensure all hardware items have been included refer to assembly diagram.
2. It is recommended that the instructions are read through and completely understood before making any attempt to fit this product.
3. Be wary of any changes to vehicle designs or other accessories that may conflict with the installation of this product.
4. Before drilling ensure that the area is clear of fuel, electrical & other components.
5. All holes drilled into the body panels shall have all burrs & swarf removed then coated with a suitable rust preventative paint.
6. For vehicles that require the bumper to be cut. Ensure cut out area is in correct position on the vehicle prior to cutting the bumper.
7. The high tensile fasteners supplied with this product were used to achieve the specified rating. If replacement is required ensure that fasteners of the same rating & quality are used. Contact an authorized **Trailboss** dealer if further information is required.
8. Ensure that all hardware is fastened to torque list below check fasteners on regular basis.
9. Tow bar load rating sticker provided with this product shall be conspicuously located on inside rear end of the driver's door. **(See diagram below).**
10. Trailboss recommends that you check your tow ball to ensure that it complies with the Australian standards **AS 4177.2.**
11. **PLEASE NOTE:** It is advised to remove your lug or tbn when not actually towing so as to produce a clear view of the vehicles registration plate if obscured, and to also provide maximum available departure angle
12. Pull Pin must be fit in down position.

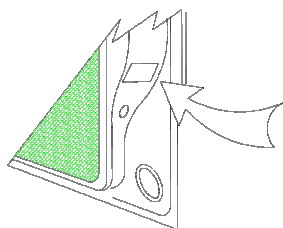

Place load rating sticker
inside driver's door here

FOR TRAILER TOWING PURPOSES ONLY
For towing capacity details please refer to vehicle owner's manual or to the manufacturer. Overloading can void your warranties.

RECOMMENDED ASSEMBLY TORQUE LISTING

Diameter	Grade 8.8 Bolt
M6	9.5 Nm
M8	21.7 Nm
M10	43.4 Nm
M12	77.3Nm
M14	146 Nm
M16	189.8 Nm

Tow bar Maintenance and Care.

Trailboss recommends that bolt torque's, as listed below, are routinely and regularly inspected and checked for correct tension. Replace any worn or defective parts.

We recommended to remove Tow Ball Mounts (TBM's, tongues or lugs) when not being used for any considerable length of time.

So as to avoid injury, when not towing it is suggested that the tongue, Pull Pin and R-clip are removed then stored in a safe, clean and dry place, away from excessive moisture.

Hitch Pull Pins and spring "R" clips are regularly checked for proper installation. Replace any worn or defective parts.

TRAILBOSS

Towbar Fitting Instructions
 To Suit **PEUGEOT 508 MY12 ON**
 Part Number **QTPG2L**
 Rating **1900/75 kg**

PLACE THESE INSTRUCTIONS IN THE VEHICLE'S GLOVEBOX AFTER INSTALLATION IS COMPLETE

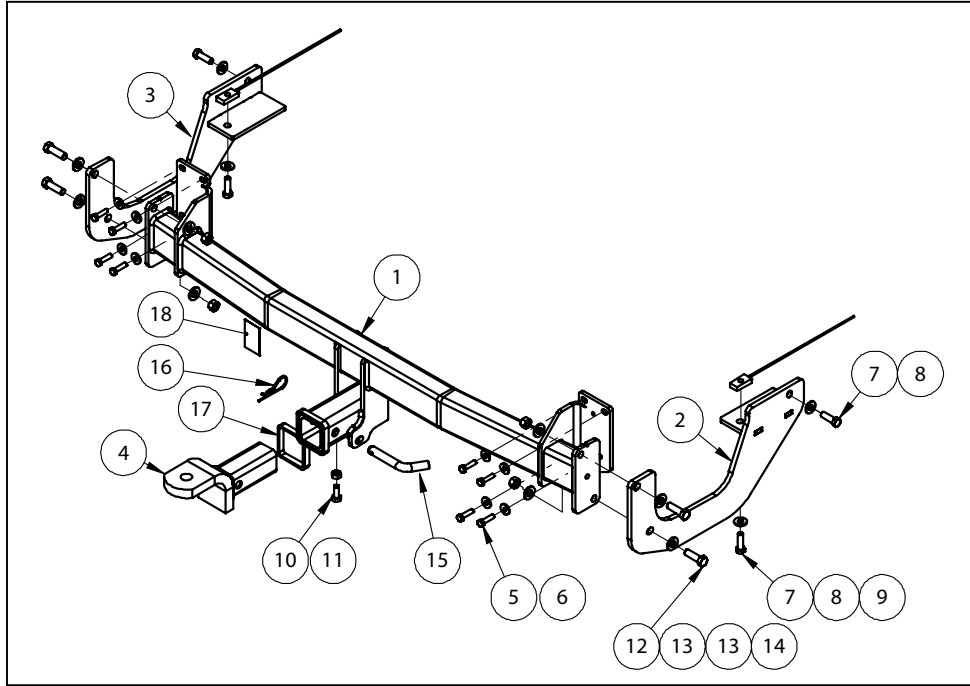

QTY.	DESCRIPTION	ITEM NO.
1	WELDED ASSY	1
1	DRIVERS SIDE BRACKET	2
1	PASSENGER SIDE BRACKET	3
1	TBM	4
8	BOLT HEX M8-1.25x30mm	5
8	M8x22x3.3mm FLAT WASHER	6
4	M10-15x35mm SET SCREW	7
4	WSHR FT M10x25.4x3	8
2	T PLATE 20x10x40 M10 1.5P & WIRE W300	9
1	BOLT M10-1.50x25	10
1	HEX NUT M10x1.5	11
4	SET SCREW M12x40x1.75P	12
8	WASHER FLAT 1/2"x1 1/8"x1/8"	13
4	M12x1.75 HEX NUT PC8	14
1	PULL PIN	15
1	R CLIP	16
1	COLLAR COVER	17
2	ACRYLIC CP LABEL	18

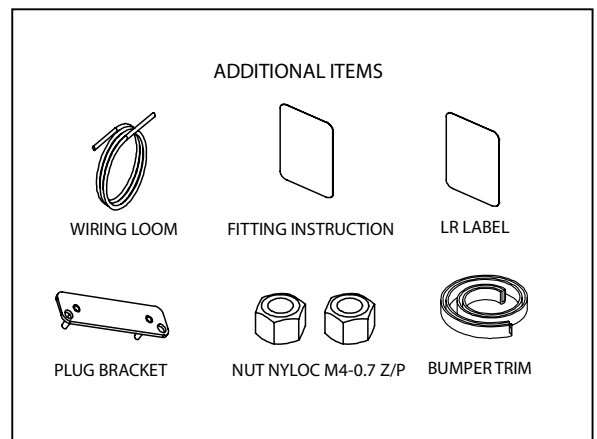

TRAILBOSS

Towbar Fitting Instructions
To Suit PEUGEOT 508 MY12 ON
Part Number QTPG2L
Rating 1900/75 kg

PLACE THESE INSTRUCTIONS IN THE VEHICLE'S GLOVEBOX AFTER INSTALLATION IS COMPLETE

INSTRUCTION:

1. Remove 2x Screws from inside Wheel Arc for both LH & RH side, also remove 1x Screw behind the Wheel Arc Lining for both LH & RH side.
2. Open Rear Light Cavity and remove Plastic Nut and disconnect Rear Light Plug for both LH & RH side, firmly pull on light to remove.
3. Remove 1x Screw from Bumper Bar for both LH & RH side. Remove 1x Nut from underneath Bumper Bar then firmly pull on Bumper to release from Clips.
4. Remove 3x Scrivets and 2x Screws from Internal Bumper Clip Plate and remove 4x Bolts from Impact Beam and discard Beam and Bolts.
5. Firmly Bolt centre section of Towbar on to vehicle.
6. Loosely Bolt the Side Arms to the Bar and Chassis Rail. Use the hole in the bottom of the Side Arm to use as a guide to drill the hole into the Chassis Rail.
7. Drill out the existing hole in the bottom of the Chassis to 24mm diameter and feed the Tapped Plate through the hole and tighten all the Bolts to the torque specifications provided on Page1.Coat all bare metal with rust proofing paint.
8. Created a Bumper Cut in the centre of the Bumper 100mm wide and 185mm high.
9. Reassemble all parts in reverse order to disassembly.

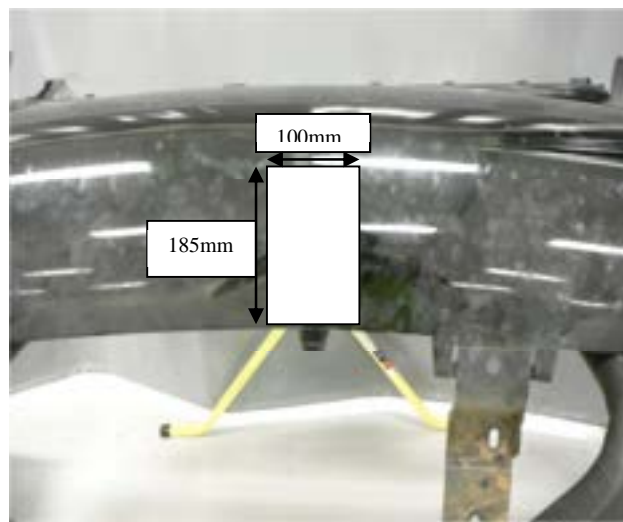



Wiring Loom Fitting Instructions
To Suit Peugeot 508 Wagon
Part Number 100881-WL

Wiring Loom Installation Instructions

Peugeot 508 Wagon
Part No: 100881-WL

Tail Harness Length Required: 1800mm
ECU Required: 04826

Wiring Loom Installation Time: Approx 30 Mins

Wiring Loom Fitting Instructions To Suit Peugeot 508 Wagon Part Number 100881-WL

1. In the luggage compartment, remove the floor carpet cover.
2. Remove the two screws behind the cargo hooks.
3. Remove the luggage compartment rear trim by pulling in an upwards direction.
4. On the upper LHS luggage compartment trim, remove the plastic cover.
5. Remove the four the screws.
6. Remove the lever arm.
7. Remove the upper luggage compartment panel.

Note: Disconnect the 12v light before dislodging.

Repeat Steps 4-7 for the RHS.

8. On the LHS rear quarter panel, drill a Ø30mm hole next to the air vent.



9. In the LHS of the luggage compartment, disconnect the tail light assembly connectors and connect the trailer patch in between.
10. Connect the trailer patch ground ring terminal to the existing vehicle grounding point.
11. Connect the trailer patch 12-way connector to the ECU.
12. Apply double sided tape to the ECU (04826) and secure it to the vehicle sheet metal on the LHS of the luggage compartment.

Note: Ensure the ECU connector is facing downwards.



Wiring Loom Fitting Instructions
To Suit Peugeot 508 Wagon
Part Number 100881-WL

13. On the vehicle's existing harness, following the table below, connect the ezy-tap to the vehicle's GREEN/BLACK reverse wire, then connect the trailer patch terminal to the ezy-tap.

Function	Trailer Patch	Vehicle Connector
REVERSE	BLACK / WHITE	GREEN / BLACK

14. Route the trailer patch towards the RHS of the vehicle.
15. Disconnect the RHS tail light assembly connectors and connect the trailer patch connectors in between.
16. In the engine bay, remove the battery cover and connect the power harness positive ring terminal to the vehicle's vacant battery slot.
17. Route the power harness underneath the engine bay towards the rear of the vehicle.
18. Continue routing the power harness along the chassis rail towards the rear of the vehicle.
- Note: Ensure to secure the power harness away from any moving objects or sources of heat.**
19. Mount the trailer socket to the towbar mounting bracket using M4 fasteners (not supplied).
20. Route the tail harness across the towbar towards the LHS of the vehicle and up through the previously drilled out hole.
21. Ensure the tail harness grommet is seated correctly and secure in place using a cable tie (not supplied).
22. Pierce a hole in the grommet and feed the 12v power harness through into the vehicle luggage compartment.
23. Connect the power harness 1-way male connector to its mating 1-way female trailer patch connector.
24. Connect the tail harness 8-way connector to the trailer patch mating 8-way connector.
25. Test the trailer wiring harness function using a light board or multimeter.
26. Secure all harnesses using cable ties (not supplied).
27. Re-fit all removed parts and secure all fasteners, ensuring there are no squeaks or rattles.
28. Place the fitting instructions in the glove box after fitment.