



TOWBAR INSTALLATION INSTRUCTIONS

PART NUMBER QTJP25L

JEEP GRAND CHEROKEE WL SWB CL4

PRODUCT DETAILS:

Part Number:	QTJP25L	Maximum Towing Braked:	2813	kg
ECU Number:	04826	Maximum Towing Unbraked:	750	kg
Tail Harness Length Required:	400 mm	Maximum Static Ball Load:	281	kg
TBM/Lug Part Number:	21141			

FITTING DETAILS:

Towbar Installation Time:	90 Mins.	RPA Disable/Other:	YES
Total Installation Time:	150 Mins.		
Bumper Cut Required:	No		

Note:

- Switch on top of infotainment screen

TRAILBOSS RECOMMENDS THAT INSTRUCTIONS ARE READ AND UNDERSTOOD COMPLETELY PRIOR TO FITMENT.

BEFORE YOU START:

Check all hardware items have been included refer to assembly diagram.
Please ensure this towbar is only fitted to vehicle models as per Trailboss application guide.

Bumper Cuts

Vehicle and bumper variations can and do occur during vehicle manufacture after initial towbar design. Fitment of towbar to vehicle and accuracy of bumper cut must be assessed prior to any bumper modifications made. Incorrect bumper cuts are not covered under Trailboss warranty.

NOTE: Bumper cuts need to be approached with care, refer to notes below.

- Bumper centreline – where the centreline of the bumper needs to be determined, the installer must assess centre point by measurement of bumper width or determining two symmetrical reference points to give centreline.
- Bumper edge – To assist with accurate bumper cut measurement, reference to the start of the bumper edge is now being commonly used.
 - Measure from bottom edge along bumper and around corner to the 70 mm point (Figure 1).
 - Do not measure from visible bumper front of corner, upwards (Figure 2).

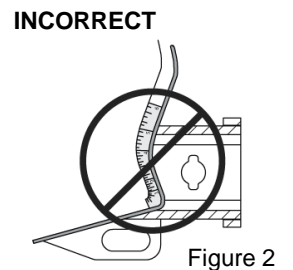
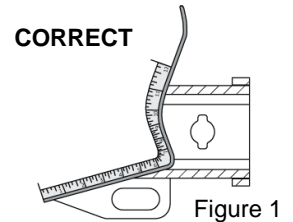

Drilling

- For any required drilling during installation, ensure that the area is clear of fuel, electrical & other components that may be damaged.
- All holes drilled into metal body panels shall have all burrs & swarf removed then coated with a suitable rust preventative paint.

Bolts/Fasteners

- Ensure that all hardware is fastened to correct torque as specified in this fitting instruction.
- All fasteners supplied with this product are used to achieve a specified clamp loading. If replacement is required ensure that fasteners of the same grade and class are used.

NOTE: Achieving correct torque is critical to proper installation and responsibility of the installer. Towbar failures attributed to tension issues from over tightening or under tightening are not covered by Trailboss warranty.

Product Labels

- a. Towbar load rating sticker provided with this product shall be conspicuously located on inside rear end of the driver's door.

WARNING:

Do not, drill, cut, weld or otherwise modify the towbar.

FOR TOWING PURPOSES ONLY - This towbar is designed and tested by Trailboss to adhere to ADR 62/02 which provides only for the expected load demands of towing.

i TOWBAR ASSEMBLY DIAGRAM

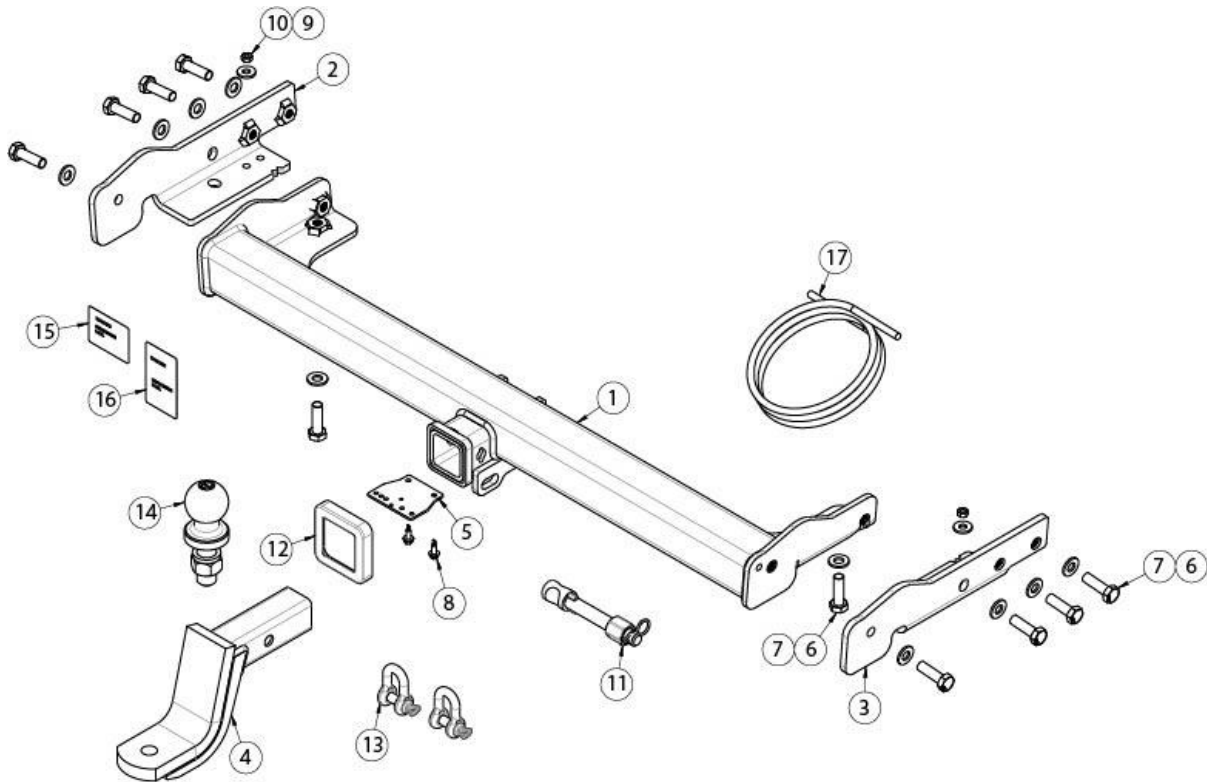

ITEM	DESCRIPTION	QTY
1	JEEP CHEROKEE WELDED ASSEMBLY	1
2	SIDE ARM ASSEMBLY, LH	1
3	SIDE ARM ASSEMBLY, RH	1
4	TRAILER BALL MOUNT	1
5	PLUG BRACKET	1
6	WASHER PLAIN M14x28x3	10
7	SET SCREW HEX HD M14x45x2P	10
8	TEK SCREW 14-20 HEX HD 22mm	2
9	WASHER PLAIN M10x25x3	2

ITEM	DESCRIPTION	QTY
10	NUT HEX HD M8x1.25P	2
11	SMART PIN SILVER	1
12	HITCH BOX COLLAR COVER	1
13	"D" SHACKLE 10mm	2
14	TOWBALL 50mm	1
15	COMPLIANCE LABEL	1
16	LOAD RATING LABEL	1
17	WIRING LOOM	1

1. Move the Passenger Front Seat forward.
2. Remove the Air Duct (1).
3. Remove the Battery Cover (2) by lifting up with a trim removal tool.
4. Disconnect the vehicle battery Negative Terminal (3).

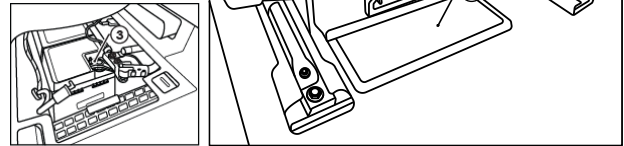

5. Open tailgate, remove the 1 x scrivet and the plastic cover.
6. On the bumper section, unclip the fastener cover and remove the exposed 1 x bolt.

Repeat for other side.

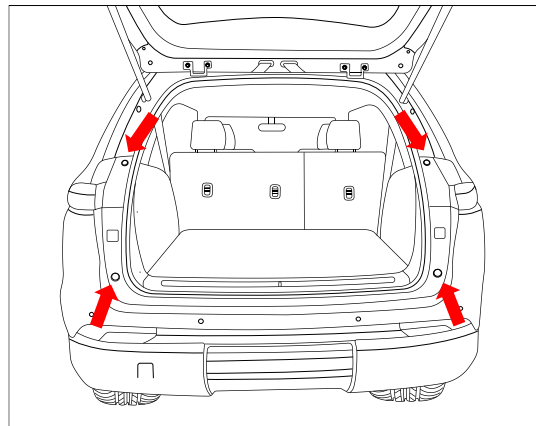

7. Remove the 1 x exposed Torx.
Remove light assembly by pulling outwards from vehicle and disconnect from the electrical connector.

Repeat for other side.

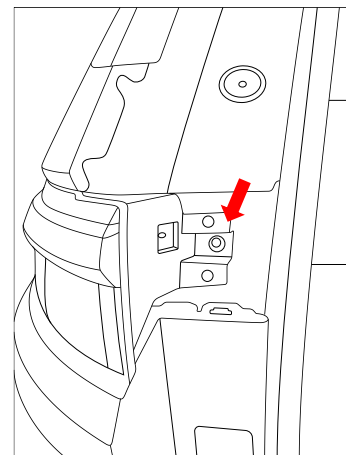

-
8. On the underside of the bumper, remove 4 x bolts securing bumper.

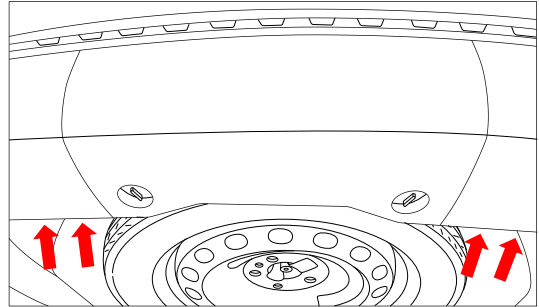

-
9. In the wheel arch, remove 4 x screws.

Repeat for other side.

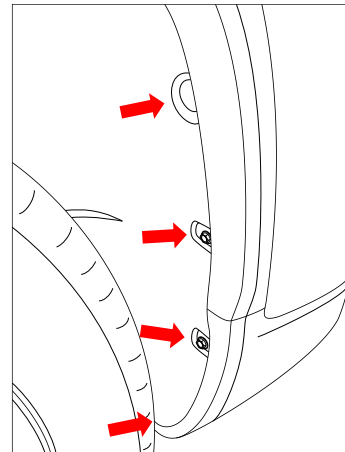

-
10. Remove the wheel arch skirt secured with 7 x grommets and 4 x (green) clips.
TIP: Use an 8mm socket to push out the grommets from the body.
(Image indicates positions with the wheel skirt removed).

11. Remove the exposed 1 x bolt securing the bumper.

Repeat steps 6 and 7 for other side.

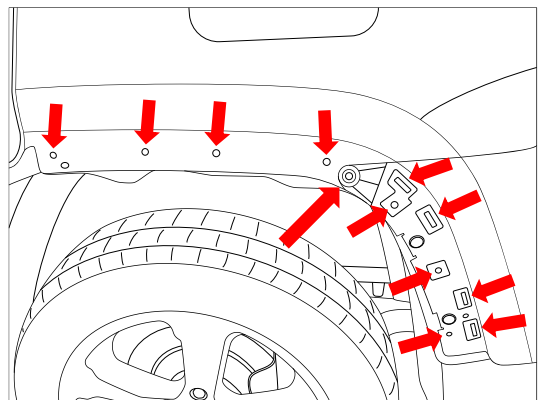

12. Peel the bumper away from each side and disconnect the exposed 1 x wiring loom. (Both sides have a connector).
13. Continue to remove the bumper from vehicle. The luggage section of the bumper may require extreme force (rearwards) to unclip from the retainers.

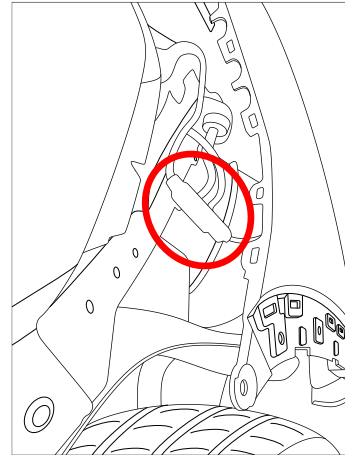

14. Remove and retain the 1 x bolt securing the exhaust support bracket. Repeat for other side.
15. Remove and discard the impact beam, secured with 3 x bolts per side.

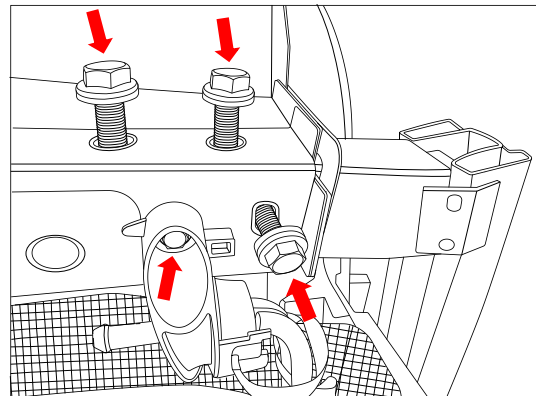

16. Insert the side arm assembly into the chassis rail and loosely secure the most forward positions to the side with 2 x M14 bolts complete with 1 x washer per bolt.
17. Loosely secure the exhaust support bracket with the retained bolt along with the supplied M8 nut complete with 1 x washer.

Repeat both steps for the other side.

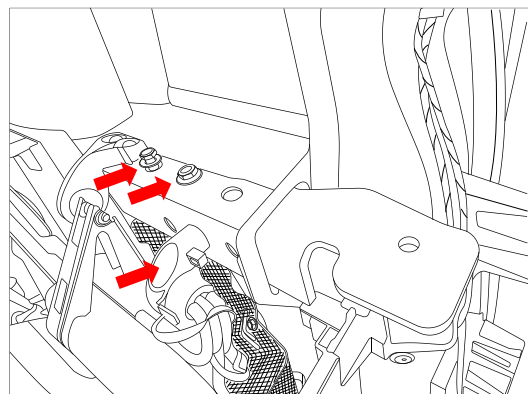

18. Position the crosstube assembly onto the side arm assemblies and loosely secure to the side of the crosstube assembly with 1 x M14 bolt complete with 1 x washer.
19. Loosely secure the complete assembly to the chassis underside with 1x M14 bolt complete with 1 x washer and to the side of the chassis with 1x M14 bolt complete with 1 x washer.

Repeat steps 14 to 15 for the other side.

Tighten all the fasteners to the following torque.

M8 x1.25 Gr8.8 : 22Nm

M14 x 2 Gr10.9 : 175Nm

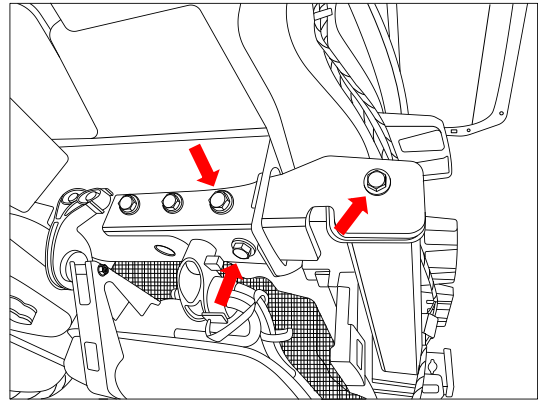

20. Secure the plug plate to the crosstube assembly with 2 x tek screws.

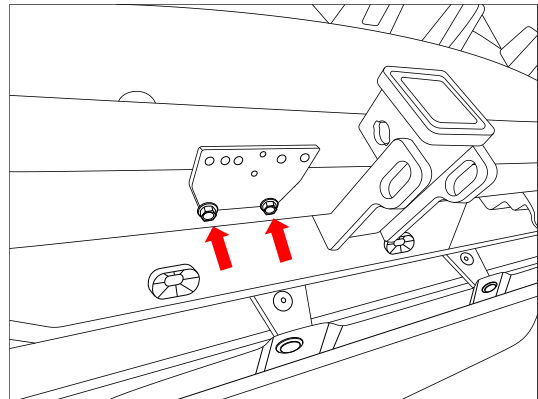

IMPORTANT

Due to possible vehicle variations, always confirm any noted vehicle colour wires with a multi-meter to ensure the correct function is identified before soldering or scotch locking. For vehicle wires denoted with two colours (example; RED/GREEN) the first colour will always be the main wire colour while the second colour is the thinner trace colour on the wire.

21. In the luggage compartment, fold down the Rear Seats (1).
22. Remove the Floor Carpet (2).
23. Remove Rear Cargo Blind (3) if fitted.

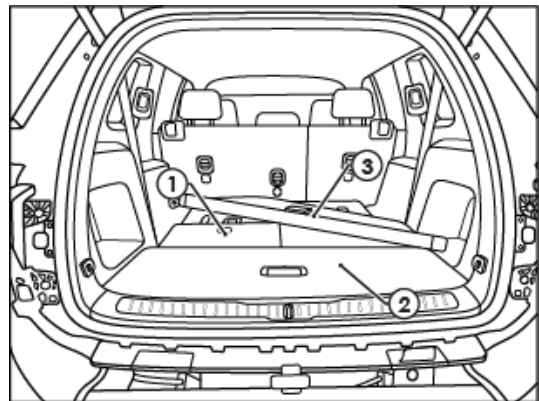

24. Remove Vehicle Jack (1).
25. Remove 2x Nuts (2) and 2x Screws (3) securing the Spare Tyre Compartment Trim (4).
26. Remove the Spare Tyre Compartment Trim (4).

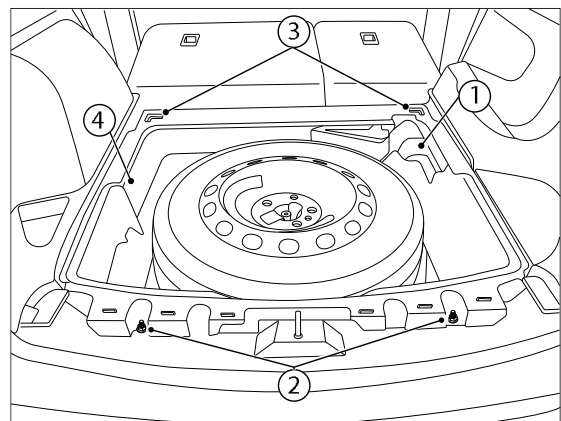

27. Dislodge the LHS corner of the Rear Door Seal (1).
28. Dislodge the Upper Luggage Compartment Trim (2).
29. Remove the Lower Luggage Compartment Trim (3) and disconnect the 12V DC socket connector behind the trim.
30. Leave the Lower Luggage Compartment Trim hanging with the seatbelt to allow access to the rear LHS corner.

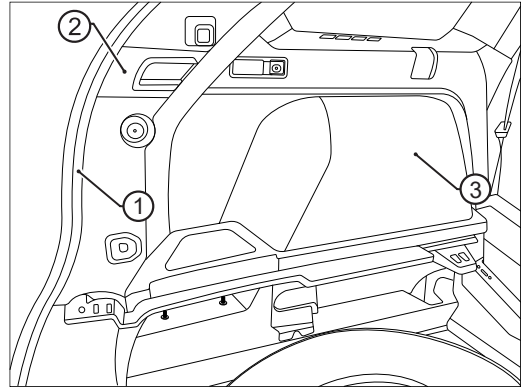

31. With the rear bumper removed, drill a 30mm hole in a suitable location (1) on the LHS Rear Quarter Panel.

Note: File any rough or sharp edges, spray rust inhibitor.

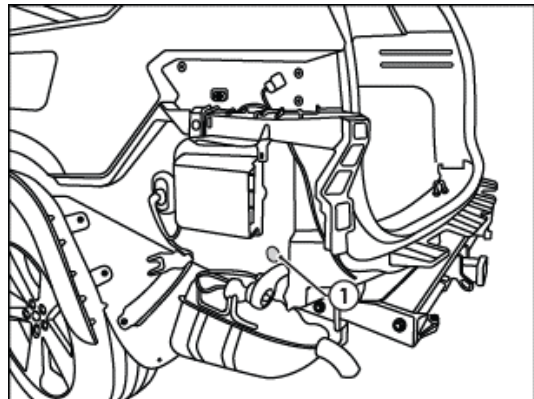

32. With the tail lights removed, patch in the LHS Tail Light Connectors (1) on the Trailer Patch (102710-WL) in between the LHS Tail Light Wiring and the Vehicle Body Wiring (2).

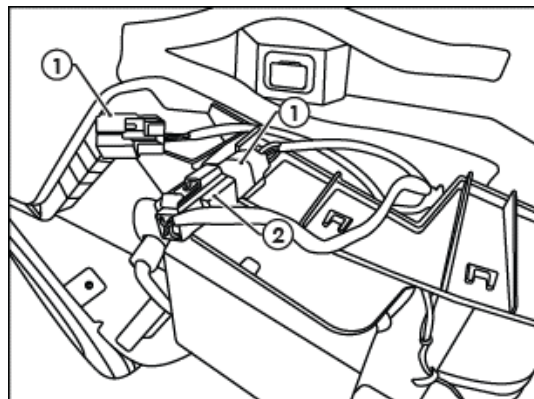

33. Continue routing the Trailer Patch (102710-WL) across the rear of the Vehicle towards the RHS Taillights.
34. Using the supplied Cable Tie Mounts secure the Harness to the Chassis.

Note: Keep harness routing clear of all sharp edges, moving parts and places of extreme heat.

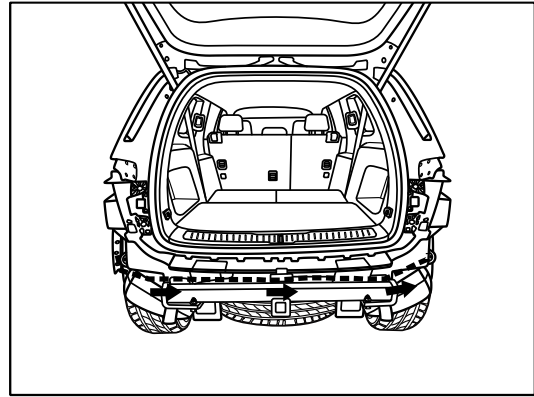

35. On the RHS Rear of the vehicle, patch the RHS Tail Light Connectors (1) on the Trailer Patch (102710-WL) in between the RHS Tail Light Wiring and the Vehicle Body Wiring (2).

Note: This step is only for reverse signal.

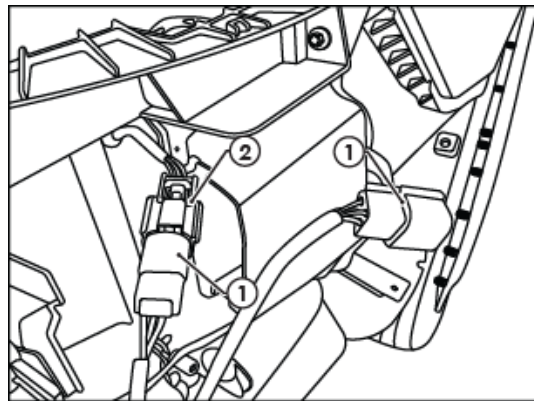

Note: This step is only for reverse signal.

36. On the RHS Rear Quarter Panel locate the 16-Way Male Connector (1).
37. Dislodge and remove the connector backshell on the Bumper Connector (1).
38. Cut open the wiring harness and locate the WHITE/PURPLE wire (2) (Pin 15) for Reverse Signal.
39. Following the Table below, use the supplied EZY-Tap (3) at approximately 100mm from the back of the bumper connector on the WHITE/PURPLE Wire (2).
40. Then connect the branch labelled REVERSE on the Trailer Patch (102710-WL) into the EZY-Tap.

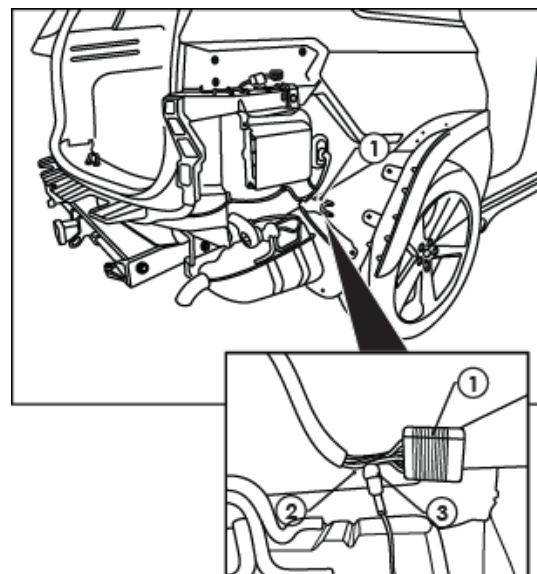

Function	Trailer Patch	Vehicle Bumper Connector
REVERSE	BLACK/WHITE	WHITE/PURPLE (Pin 15)

41. Reinstall the connector backshell on to the bumper connector.

42. On the LHS rear of vehicle, route the branch with the grommet on the Trailer Patch (102710-WL) through the previously drilled 30mm hole (1).
43. Seat grommet in 30mm hole (1).

Note: Ensure grommet is seated correctly and makes a good seal.

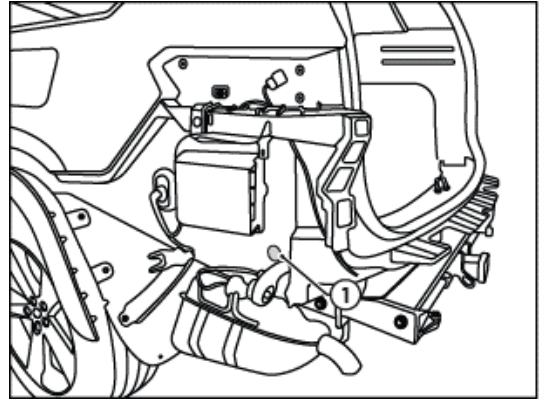

44. From inside the vehicle on the LHS Rear Compartment area, secure the Ground Ring Terminal (1) to the Vehicle Earthing Point (2).

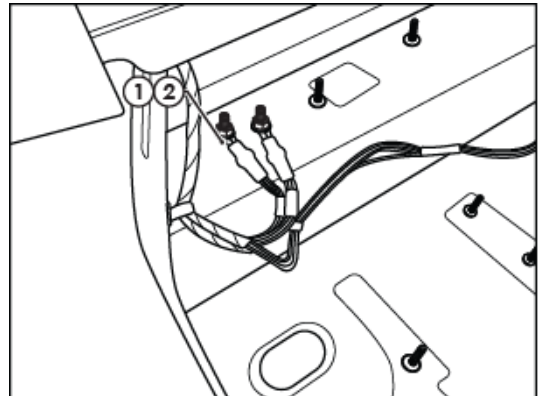

45. Using an alcohol wipe, clean the LHS Inner Sheet Metal Area (1) underneath the LHS luggage compartment trim, and the underside of the ECU (04826) (2).
46. Connect the trailer patch 12-Way Connector (3) to the ECU.
47. Apply the double-sided tape to the ECU (2) and secure it to the vehicle sheet metal, underneath the LHS luggage compartment trim.

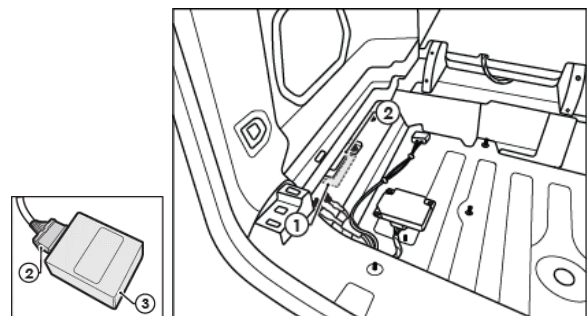

48. At the LHS rear door, dislodge the Aperture Seal (1).

49. Remove the LHS Door Sill Trim (2) by carefully pulling in an upward direction.

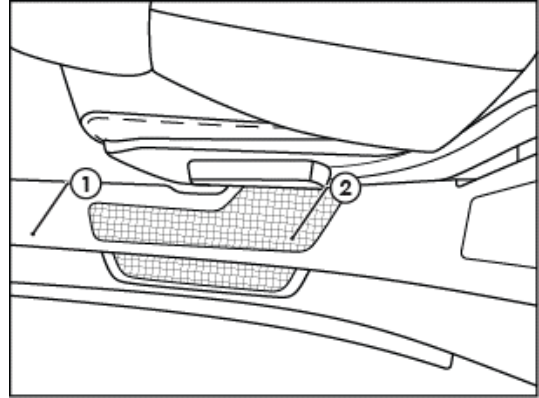

50. Using a yellow cable feeder feed the 1-way connector with Orange Wire (1) on the trailer patch (102710-WL) through the LHS Rear Compartment Trim towards the front passenger seat.

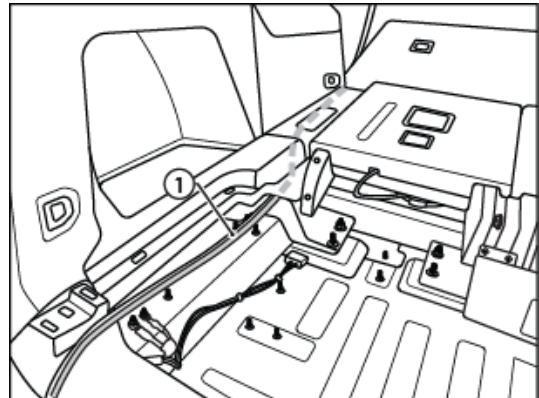

51. At the LHS rear door, continue routing 1-Way Connector (1) towards the Battery under the Front Passenger Seat.

52. Tuck the orange wire under the trim as required.

Note: Yellow Cable Feeder to be used to route Trailer Patch underneath trim.

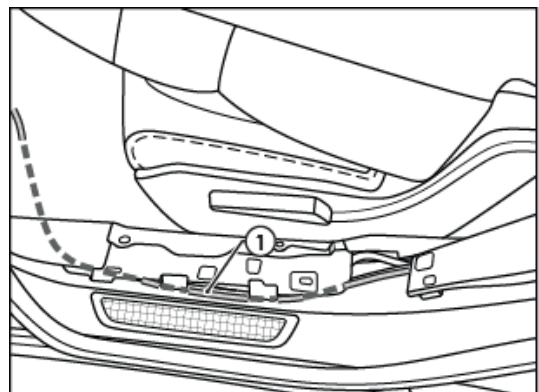

53. At the vehicle battery, Secure the Orange Power Wire Ring Terminal (1) that was supplied with the Trailer Patch.
54. Connect the 1-way connector on the trailer patch to the supplied power patch.

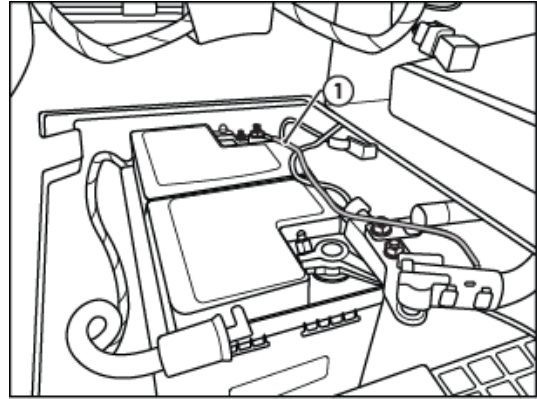

55. Connect the tail harness (tail length 400mm) 8-Way Connector (1) to the trailer patch mating 8-Way Connector (2).
56. Use Silicone Grease (3) to seal the blue connectors.
57. Secure all harnesses using supplied cable ties.

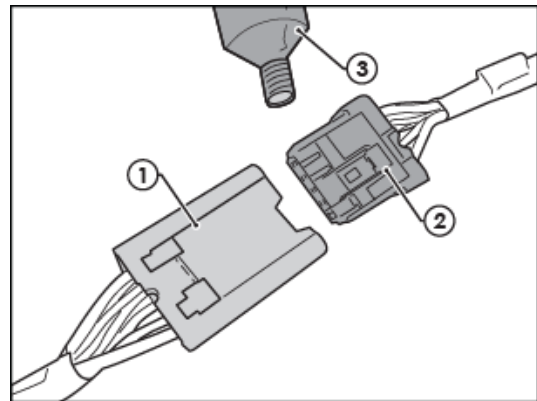

58. Remove the centre panel on the bumper secured with 2 x turn screws.
59. Refit the bumper. A small clearance cut may be required on the lip of the bumper to clear the chain mountings.

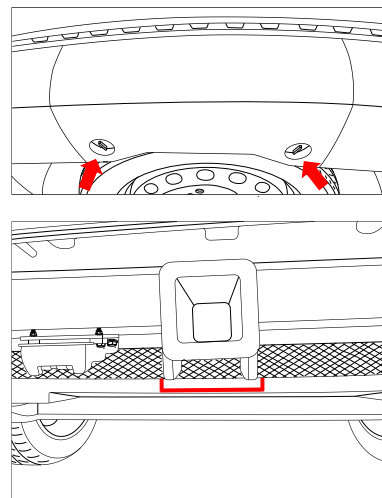

-
60. Test the trailer patch function using a light board or multi-meter.
 61. Re-fit all removed parts and secure all fasteners, ensuring there are no squeaks or rattles.
 62. The RPA function can be disabled via a Switch (4) on top of the Infotainment Screen.
 63. Place the fitting instructions in the glove box after fitment.

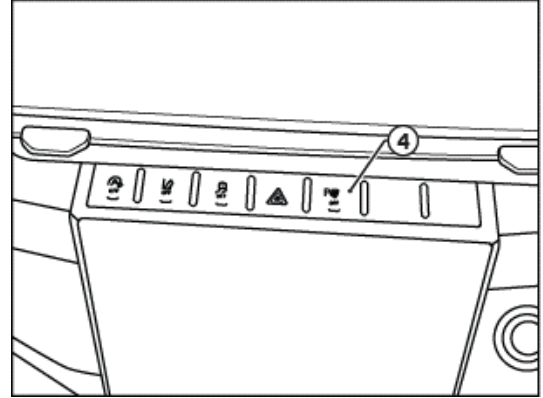



CUSTOMER INFORMATION

PLACE THESE INSTRUCTIONS IN THE
VEHICLE'S GLOVEBOX AFTER INSTALLATION

**THANK YOU FOR PURCHASING TRAILBOSS. WITH CORRECT MAINTENANCE AND CARE
THIS PRODUCT WILL PROVIDE A LIFETIME OF TROUBLE-FREE OPERATION.**

TOWBAR MAINTENANCE AND CARE:

1. Trailboss recommend that the towbar LUG or TBM (Trailer Ball Mount) Pull Pin and R-clip are removed and stored when not in use. Removal of LUG or TBM (Trailer Ball Mount) is advisable when not in use to assist with any of the following.
 - Ensure rear number plate is not obscured.
 - Allow maximum available departure angle and prevent any potential interference.
 - Prevent possible interference with vehicles reverse sensors or camera detecting a tow ball mount as an obstruction during reversing.
 - Removes towball mount as an obstruction for when moving around the rear of the vehicle.
2. Trailboss recommends routine inspection of your towbar to ensure trouble free towing.
 - Bolt security and tension should be regularly inspected and checked for correct tension. Replace any worn or defective parts with suitable grade & class fasteners. Inspection should be requested to coincide with vehicle major services.
3. It is the owner's responsibility to ensure towing and down ball weight capacities of the towing vehicle are not exceeded.
 - Towing and down ball weights allowable may differ according to model variations. Please refer to owner's manual or vehicle dealer to confirm exact rating for your vehicle model variant.
 - It is not uncommon for the vehicle tow rating to differ from the towbar rating. When this occurs, the lesser rating must be adhered to.
 - For vehicles fitted with enhanced vehicle functions that may be altered/changed when towing i.e Trailer sway mitigation, blind spot detection, adaptive cruise control etc. Please consult owner's manual to understand changes enabled when towing and after towing.

WARRANTY INFORMATION:

Trailboss Towbars are covered by a Lifetime Warranty.

Our goods come with guarantees that cannot be excluded under the Australian Consumer Law. You are entitled to a replacement or refund for a major failure and for compensation for any other reasonably foreseeable loss or damage. You are also entitled to have the goods repaired or replaced if the goods fail to be of acceptable quality and the failure does not amount to a major failure.

For further details please contact customer service on 1800 812 017.

PRO SERIES SILENT ANTI-RATTLE HITCH PIN

Your Trailboss towbar is equipped with a Pro Series Silent Anti-Rattle Hitch Pin technology to help reduce towbar tongue rattle in most driving conditions. Please ensure below instructions are understood and routine maintenance is carried out to ensure best towing experience.

Regularly inspect for wear and check the tightness of the Silent Anti-Rattle Hitch Pin. Follow instructions below to re-tighten the nut as necessary when movement and noise in the tow ball mount is noted.

- Before towing, ensure R-Clip is properly installed and hitch pin nut is installed and tensioned. Replacement parts are available from your Pro Series Distributor.

TOWBALL MOUNT REMOVAL/INSTALLATION

STEP 1

Insert Trailer Ball Mount (TBM) (a) into towbar hitchbox (b), aligning hole in TBM shank (c) with hole in hitchbox (d) (Fig. 1)

STEP 2

Insert Silent Anti-Rattle Hitch Pin (e) through hole in hitchbox and hole in TBM shank (g); ensure the locators are inserted into the notches in the hitchbox (Fig. 2)

STEP 3

Screw Silent Anti-Rattle Hitch Pin Nut (f) onto Smart Pin (g); tighten Smart Pin Nut until finger tight, ensuring TBM is restrained from up and down movement.

STEP 4

Tighten Silent Anti-Rattle Hitch Pin Nut by turning nut a further 1/8th of a turn in the clockwise direction using a 24mm spanner (Fig. 4).

STEP 5

Install Silent Anti-Rattle Hitch Pin R-Clip through the hole that provides best clearance or easiest access. (Fig. 5)

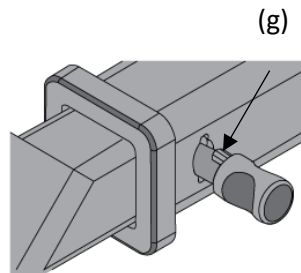
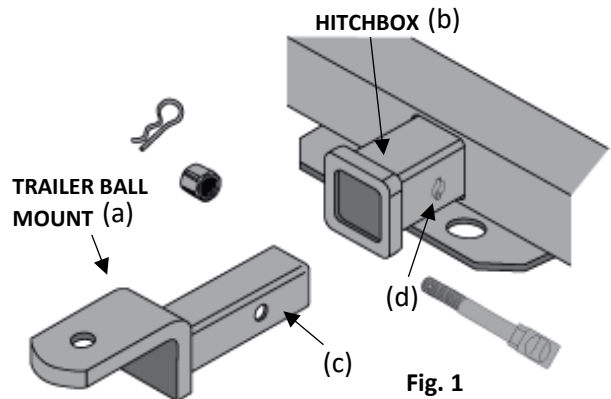

Fig. 2

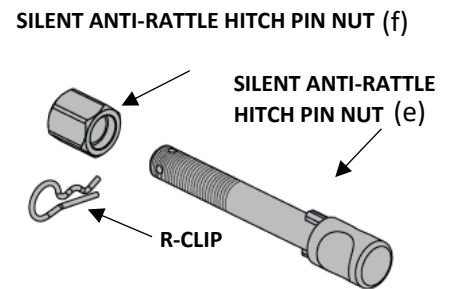

Fig. 3

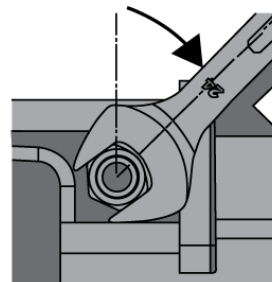

Fig. 4

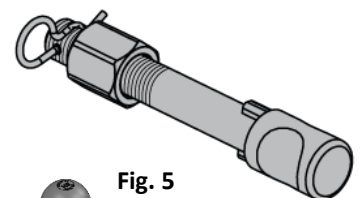

Fig. 5

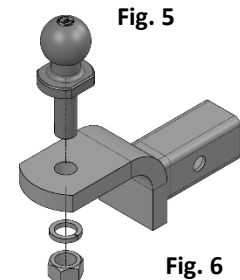

Fig. 6