

TRAILBOSS

Towbar Fitting Instructions
To Suit **HYUNDAI TUCSON TL & TLe SERIES**
Part Number **QTHY264L**
Rating **1600/140 kg**

PLACE THESE INSTRUCTIONS IN THE VEHICLE'S GLOVEBOX AFTER INSTALLATION IS COMPLETED

WARNING:

1. Do not, drill, cut, weld or otherwise modify the tow bar.
2. If you are using electric welding on a motor vehicle, **always** check that the vehicle is not equipped with electronic engine or instrument management equipment. Failure to do so could **destroy** any onboard computers. If in doubt, check with the vehicle's manufacturer.
3. The high tensile fasteners supplied with this product were used to achieve the specified rating. If replacement is required ensure that fasteners of the same rating & quality are used. Contact an authorised **Trailboss** dealer if further information is required.
4. If TBM is used in inverted position tow ball may make contact with rear tailgate when lowered, which could cause damage.

General:

1. Ensure all hardware items have been included refer to assembly diagram.
2. It is recommended that the instructions are read through and completely understood before making any attempt to fit this product.
3. Be wary of any changes to vehicle designs or other accessories that may conflict with the installation of this product.
4. Before drilling ensure that the area is clear of fuel, electrical & other components.
5. All holes drilled into the body panels shall have all burrs & swarf removed then coated with a suitable rust preventative paint.
6. For vehicles that require the bumper to be cut. Ensure cut out area is in correct position on the vehicle prior to cutting the bumper.
7. The high tensile fasteners supplied with this product were used to achieve the specified rating. If replacement is required ensure that fasteners of the same rating & quality are used. Contact an authorized **Trailboss** dealer if further information is required.
8. Ensure that all hardware is fastened to torque list below check fasteners on regular basis.
9. Tow bar load rating sticker provided with this product shall be conspicuously located on inside rear end of the driver's door. **(See diagram below).**
10. Trailboss recommends that you check your tow ball to ensure that it complies with the Australian standards **AS 4177.2**.
11. **PLEASE NOTE:** It is advised to remove your lug or tbm when not actually towing so as to produce a clear view of the vehicles registration plate if obscured, and to also provide maximum available departure angle
12. Pull Pin must be fit in down position.

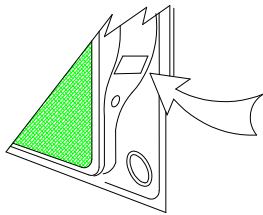

Place load rating sticker
inside driver's door here

FOR TRAILER TOWING PURPOSES ONLY
For towing capacity details please refer to vehicle owner's manual or to the manufacturer. Overloading can void your warranties.

RECOMMENDED ASSEMBLY TORQUE LISTING

Diameter	
M6	9.5 Nm
M8	21.7 Nm
M10	43.4 Nm
M12	77.3Nm
M14	146 Nm
M16	189.8 Nm

Tow bar Maintenance and Care.

Trailboss recommends that bolt torque's, as listed below, are routinely and regularly inspected and checked for correct tension. Replace any worn or defective parts.

We recommended to remove Tow Ball Mounts (TBM's, tongues or lugs) when not being used for any considerable length of time.

So as to avoid injury, when not towing it is suggested that the tongue, Pull Pin and R-clip are removed then stored in a safe, clean and dry place, away from excessive moisture.

Hitch Pull Pins and spring "R" clips are regularly checked for proper installation. Replace any worn or defective parts.

TRAILBOSS

Towbar Fitting Instructions
 To Suit **HYUNDAI TUCSON TL & TLe SERIES**
 Part Number **QTHY264L**
 Rating **1600/140 kg**

PLACE THESE INSTRUCTIONS IN THE VEHICLE'S GLOVEBOX AFTER INSTALLATION IS COMPLETED

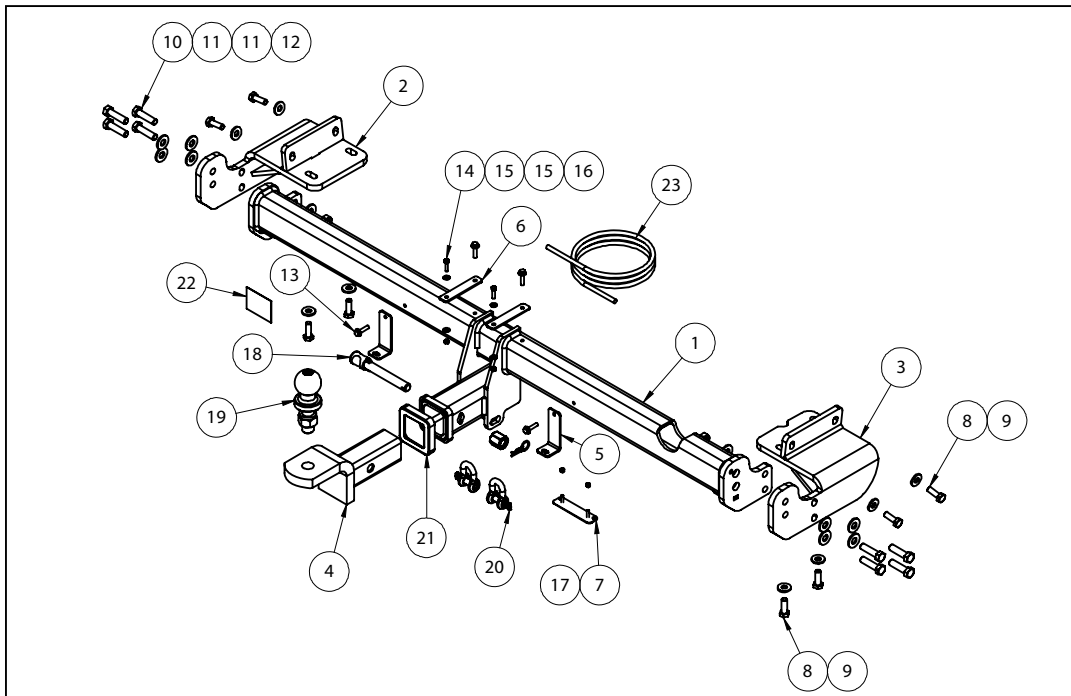

QTY.	DESCRIPTION	ITEM NO.
1	WELDE D CENTRE ASSEMBLY	1
1	LHS SIDEARM ASSY	2
1	RHS SIDEARM ASSY	3
1	TRAILER BALL MOUNT 21148	4
2	BUMPER TAB BRACKET	5
2	SMART KEY ANTENNA BRACKET	6
1	PLUG BRACKET	7
8	SET SCREW M10-1.25x30 GR 8.8 Z/P	8
8	WASHER FT M10x25.4x3	9
8	SET SCREW M12x45x1.25P G10.9	10
12	WASHER FLAT M12	11
4	HEX NUT M12x1.25 PC8	12
4	TEK SCREW 14-20 HEX HD 22mm	13
2	SET SCREW HEX HD M5x20x0.8P	14
4	WASHER FLAT M6x12.5x1.2	15
2	NUT NYLOC M5-0.8 Z/P	16
2	NUT NYLOC M4-0.7 Z/P	17
1	SILENT HITCH PIN-SILVER	18
1	50mm TOWBALL	19
2	10mm "D" SHACKLE	20
1	HITCH BOX COLLAR COVER	21
2	AGRILIC COMPLIANCE LABEL	22
1	WIRING LOOM	23



Towbar Fitting Instructions
To Suit **HYUNDAI TUCSON TL & TLe SERIES**
Part Number **QTHY264L**
Rating **1600/140 kg**

PLACE THESE INSTRUCTIONS IN THE VEHICLE'S GLOVEBOX AFTER INSTALLATION IS COMPLETED

INSTRUCTION:

1. Remove plastic trim cover adjacent to tail light assembly.
Repeat for opposite side of vehicle.
2. Remove 2x Screws securing taillights to vehicle. Remove tail light assembly.
Repeat for opposite side of vehicle.
3. Remove 2x push rivets from taillight cavity.
Repeat for opposite side of vehicle.
4. Remove 4x Screws within rear wheel arch.
Repeat for opposite side of vehicle.
5. Remove 2x Screws adjacent to chassis rail, securing rear impact beam to rear the panel.
Repeat for opposite side of vehicle.
6. Remove 3x push rivets under vehicle behind rear wheel arch and 1x push rivet from within rear wheel arch.
Repeat for opposite side of vehicle.
7. Remove plastic undertray from behind rear wheel arch.
Repeat for opposite side of vehicle.
8. Carefully unclip and remove rear bumper; disconnecting any applicable wiring looms.
9. Remove 3x push rivets securing impact beam bumper tabs to bumper.
10. Remove 2x clips securing top of impact beam to bumper.
11. Where applicable, release smart key antenna from impact beam.
12. Detach wiring from impact beam and remove and discard impact beam from rear bumper.
13. Loosely secure sidearm to side face of chassis rail using 2x M10 Screws, complete with 1x Flat washer per Screw.
Repeat for opposite side of vehicle.
14. Loosely secure sidearm to underside of chassis rail using 2x M10 Screws, complete with 1x Flat washer per Screw.
Repeat for opposite side of vehicle.
15. Loosely secure welded assembly to sidearms using 4x M12 Screws per side arm, complete with 2x Flat washer and 1x M12 Nut per 2 of the Screws, and 1x Flat washer per the remaining 2 Screws.

TRAILBOSS

Towbar Fitting Instructions
To Suit **HYUNDAI TUCSON TL & TL_e SERIES**
Part Number **QTHY264L**
Rating **1600/140 kg**

PLACE THESE INSTRUCTIONS IN THE VEHICLE'S GLOVEBOX AFTER INSTALLATION IS COMPLETED

16. Tighten all screws to torque listed on page 1 of this document.
17. Where required, secure smart key antenna brackets to holes in top of towbar using Tek screws.
18. Secure bumper tab brackets in holes on rear face of towbar using Tek screws.
19. Identify centre of bumper and create bumper cut as per diagram below.
20. Mark out and drill 2x $\varnothing 5\text{mm}$ holes 69mm apart on bumper skin to support plug bracket. Feed bracket threads through drilled holes prior to reinstalling bumper.
21. Refit rear bumper by following steps 1 to 4 and 6 to 8 in reverse order.
22. Where applicable, secure smart key antenna to smart key antenna brackets.
23. Secure loose wiring to towbar using cable ties.

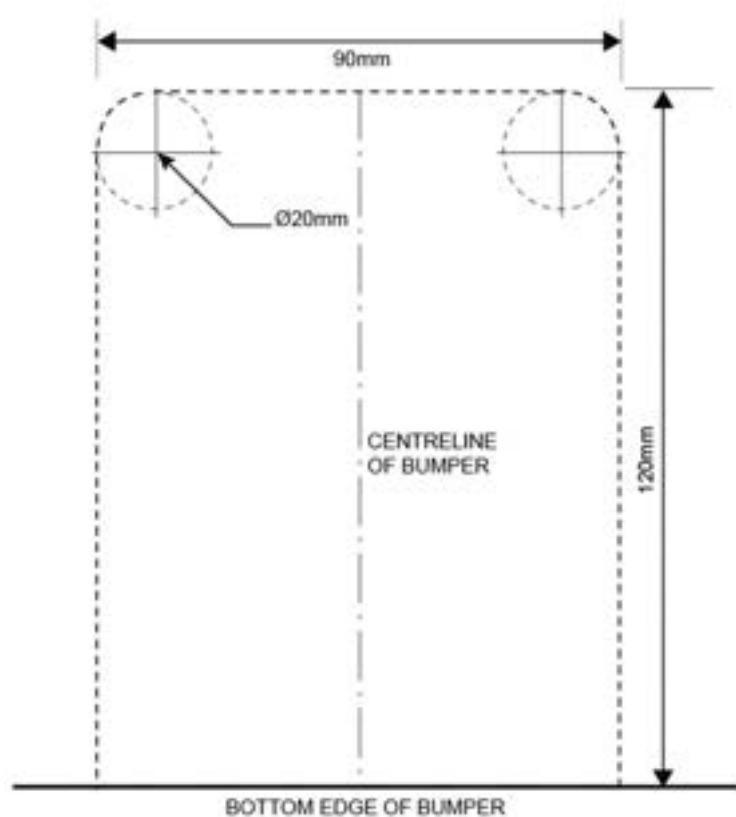

DRWING NOT TO SCALE





Wiring Loom Fitting Instructions
To Suit Hyundai Tucson TL
Part Number 201365-WL

Wiring Loom Installation Instructions

Hyundai Tucson TL
Part No: 201365-WL

Tail Harness Length Required: 1200mm
RPA Over ride Switch Part No: 04848 (if fitted)

Wiring Loom Installation Time: Approx 50 Mins

	Due to possible vehicle variations, always confirm any noted vehicle colour wires with a multi-meter to ensure the correct function is identified before soldering or scotch locking.
	For vehicle wires denoted with two colours (example; RED/GREEN) the first colour will always be the main wire colour while the second colour is the thinner trace colour on the wire.

Wiring Loom Fitting Instructions To Suit Hyundai Tucson TL Part Number 201365-WL

1. Fold down the rear passenger seats.
2. Remove the luggage compartment floor, tools jack and jack bracket.
3. Remove the rear trim and remove the two fasteners.
4. Remove the four fasteners from each side of the luggage compartment trims and then dislodge the luggage compartment trims.
5. Remove rear passenger RHS kick trim.
6. Remove the driver's door sill trim.
7. Remove the bonnet handle and then remove the driver's kick panel trim.
8. On the RHS of the luggage compartment, locate the RHS rear quarter existing grommet hole (1) and drill out to Ø30mm. Apply rust inhibitor after drilling (not supplied). If the grommet hole is occupied, pick a nearby location on the vehicle sheet metal to drill through.



9. From the vehicle interior, retrieve the vehicle RHS tail light connector.
10. Route the trailer patch (P/No:201365-WL) connectors to the retrieved RHS tail light connector and connect to the mating trailer patch connector.
11. Route the remaining trailer patch connector through the vehicle grommet hole until the trailer patch grommet is seated correctly.
12. Route the trailer patch LHS branch towards the LHS vehicle tail light area and then connect the trailer patch connector to the mating vehicle harness tail light connector.
13. Pierce a small hole into the vehicle grommet and route the trailer patch reverse terminal into the vehicle.

Wiring Loom Fitting Instructions To Suit Hyundai Tucson TL Part Number 201365-WL

14. Following the table below, connect the ezy-tap to the corresponding vehicle wire, then connect the trailer patch terminal to the ezy-tap.

Function	Trailer Patch	Vehicle Connector
REVERSE	BLACK / WHITE	RED



15. At the rear exterior of the vehicle, mount the tail harness socket to the towbar mounting bracket using M4 fasteners (not supplied).
16. Route the tail harness (tail length: 1200mm) across the RHS and up into the drilled out hole. Adjust the trailer patch harness grommet so that it is seated correctly and cable tie (not supplied) in place.
17. Connect the tail harness 8-way connector to the Trailer Patch 8-way mating connector.
18. At the RHS rear quarter interior, secure the trailer patch ground ring terminal (1) to the vehicle stud (2) (nut not supplied).
19. Route the trailer patch 1-way connector (3) along the vehicle harness, all the way towards the driver's fuse panel area.



Wiring Loom Fitting Instructions To Suit Hyundai Tucson TL Part Number 201365-WL

20. Remove the indicated vehicle 30A fuse (1). Insert the vehicle fuse 30A fuse (1) and the supplied 20A fuse (2) to the add-a-fuse harness (3). Connect the trailer patch 1-way connector (4) to the add-a-fuse harness (3). Insert the add-a-fuse harness (5) to the previously removed fuse location (6). **Ensure the add-a-fuse harness is orientated as shown.**

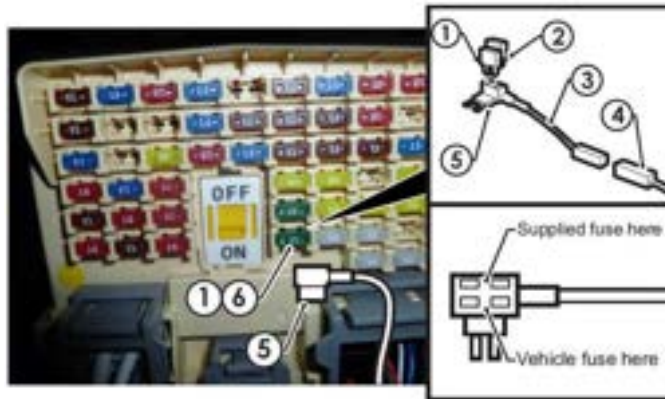

21. For RPA over ride function, locate the 13-way connector (1) at the LHS lower rear exterior of the vehicle.
22. Locate the ORANGE wire (2) on the connector and cut the ORANGE wire.

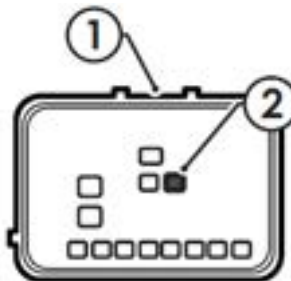

23. Patch RPA Over ride (P/No: 04848) in between the cut ORANGE wire.
24. Seal and waterproof the connection appropriately after patching.
25. Refit the tail lights.
26. Test the Trailer Harness function using a light board or multi-meter.
27. Secure all harnesses using cable ties (not supplied).
28. Re-fit removed parts and secure all fasteners, ensuring there are no squeaks or rattles.
29. Place the instructions in the glove box after fitment.



FITTING INSTRUCTIONS

Silent Anti-Rattle Hitch Pin (PR0001)

• These fitting instructions are supplied to ensure understanding of how the HITCH PIN should be fitted and used correctly.

• Once installed, we recommend **ALL** instructions are kept and placed in the vehicle glove box.

NOTE: Routine maintenance and inspection of the towbar & HITCH PIN is required. Regularly inspect for wear and check the tightness of the Hitch Pin. Follow instructions below to retighten the nut when necessary.

***Do not tow with your vehicle if the R CLIP or the HITCH PIN is loose or missing. Replacement parts are available from your Pro Series Distributor.**

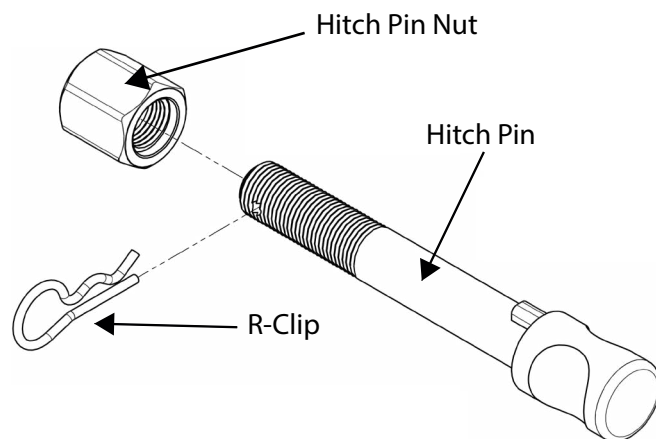

Fig 1. Silent Anti-Rattle Hitch Pin assembly

STEP 1

Insert Trailer Ball Mount (TBM) into towbar HITCHBOX, aligning hole in TBM SHANK with hole in HITCHBOX (Fig 2).

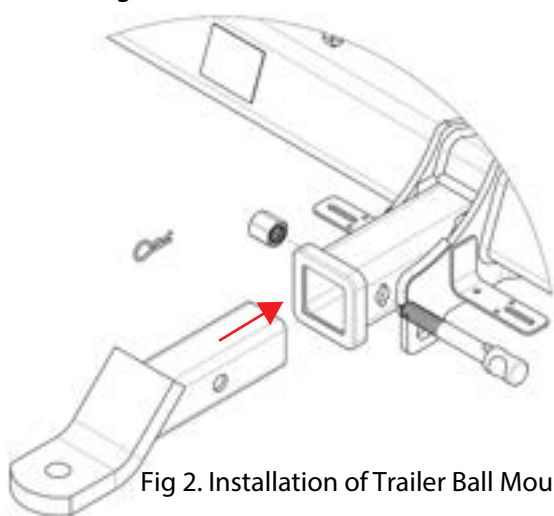

Fig 2. Installation of Trailer Ball Mount

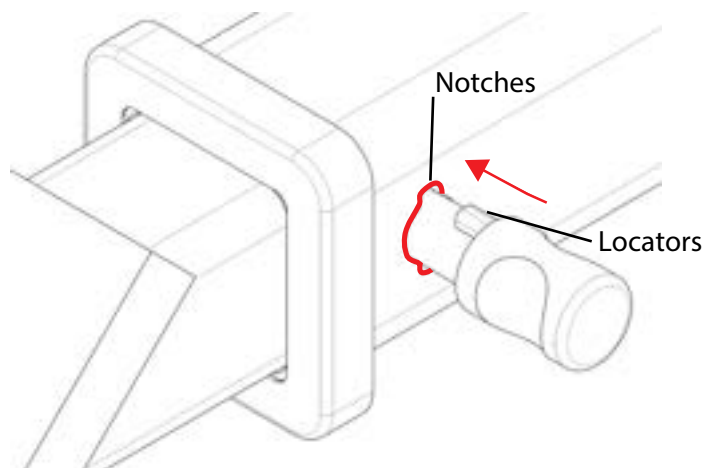

Fig 3. Silent Anti-Rattle Hitch Pin orientation

STEP 2

Insert HITCH PIN through hole in HITCHBOX and hole in TBM SHANK; ensure the LOCATORS are inserted into the NOTCHES in the HITCHBOX (Fig. 3).

STEP 3

Screw HITCH PIN NUT onto HITCH PIN; tighten HITCH PIN NUT until finger tight, ensuring TBM is restrained from movement.

STEP 4

Tighten HITCH PIN NUT by turning nut a further 1/8th of a turn in the clockwise direction using a 24mm spanner (Fig. 4).

STEP 5

Install HITCH PIN R CLIP through the hole on the HITCH PIN (Fig. 1).

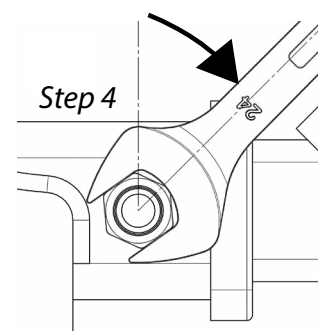

Fig 4. Tightening of Silent Anti-Rattle Hitch Pin Nut