



# TOWBAR INSTALLATION INSTRUCTIONS

PART NUMBER QTGW011L

GWM CANNON ALPHA CL4

## PRODUCT DETAILS:

Part Number:	QTGW011L	Maximum Towing Braked:	3500	kg
ECU Number:	N/A	Maximum Towing Unbraked:	750	kg
Tail Harness Length Required:	SEE NOTE	Maximum Static Ball Load:	350	kg
TBM/Lug Part Number:	21344			

## FITTING DETAILS:

Towbar Installation Time:	60 Mins.	RPA Disable/Other:	YES
Total Installation Time:	75 Mins.		
Bumper Cut Required:	No		

### Note:

- Please refer vehicles owner's manual for proper operation and understanding of towing features.
- 04943 N.O tail harness must be used for correct operation.

## TRAILBOSS RECOMMENDS THAT INSTRUCTIONS ARE READ AND UNDERSTOOD COMPLETELY PRIOR TO FITMENT.

### BEFORE YOU START:

Check all hardware items have been included refer to assembly diagram.  
Please ensure this towbar is only fitted to vehicle models as per Trailboss application guide.

#### Bumper Cuts

Vehicle and bumper variations can and do occur during vehicle manufacture after initial towbar design. Fitment of towbar to vehicle and accuracy of bumper cut must be assessed prior to any bumper modifications made. Incorrect bumper cuts are not covered under Trailboss warranty.

**NOTE: Bumper cuts need to be approached with care, refer to notes below.**

- Bumper centreline – where the centreline of the bumper needs to be determined, the installer must assess centre point by measurement of bumper width or determining two symmetrical reference points to give centreline.
- Bumper edge – To assist with accurate bumper cut measurement, reference to the start of the bumper edge is now being commonly used.
  - Measure from bottom edge along bumper and around corner to the 70 mm point (Figure 1).
  - Do not measure from visible bumper front of corner, upwards (Figure 2).

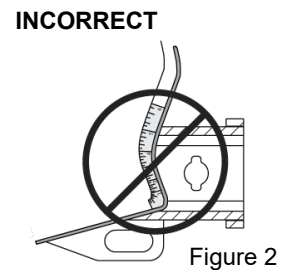
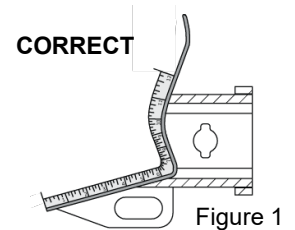

#### Drilling

- For any required drilling during installation, ensure that the area is clear of fuel, electrical & other components that may be damaged.
- All holes drilled into metal body panels shall have all burrs & swarf removed then coated with a suitable rust preventative paint.

#### Bolts/Fasteners

- Ensure that all hardware is fastened to correct torque as specified in this fitting instruction.
- All fasteners supplied with this product are used to achieve a specified clamp loading. If replacement is required ensure that fasteners of the same grade and class are used.

**NOTE: Achieving correct torque is critical to proper installation and responsibility of the installer. Towbar failures attributed to tension issues from over tightening or under tightening are not covered by Trailboss warranty.**

#### Product Labels

- a. Towbar load rating sticker provided with this product shall be conspicuously located on inside rear end of the driver's door.

### WARNING:

**Do not, drill, cut, weld or otherwise modify the towbar.**

**FOR TOWING PURPOSES ONLY - This towbar is designed and tested by Trailboss to adhere to ADR 62/02 which provides only for the expected load demands of towing.**

### **i** TOWBAR ASSEMBLY DIAGRAM

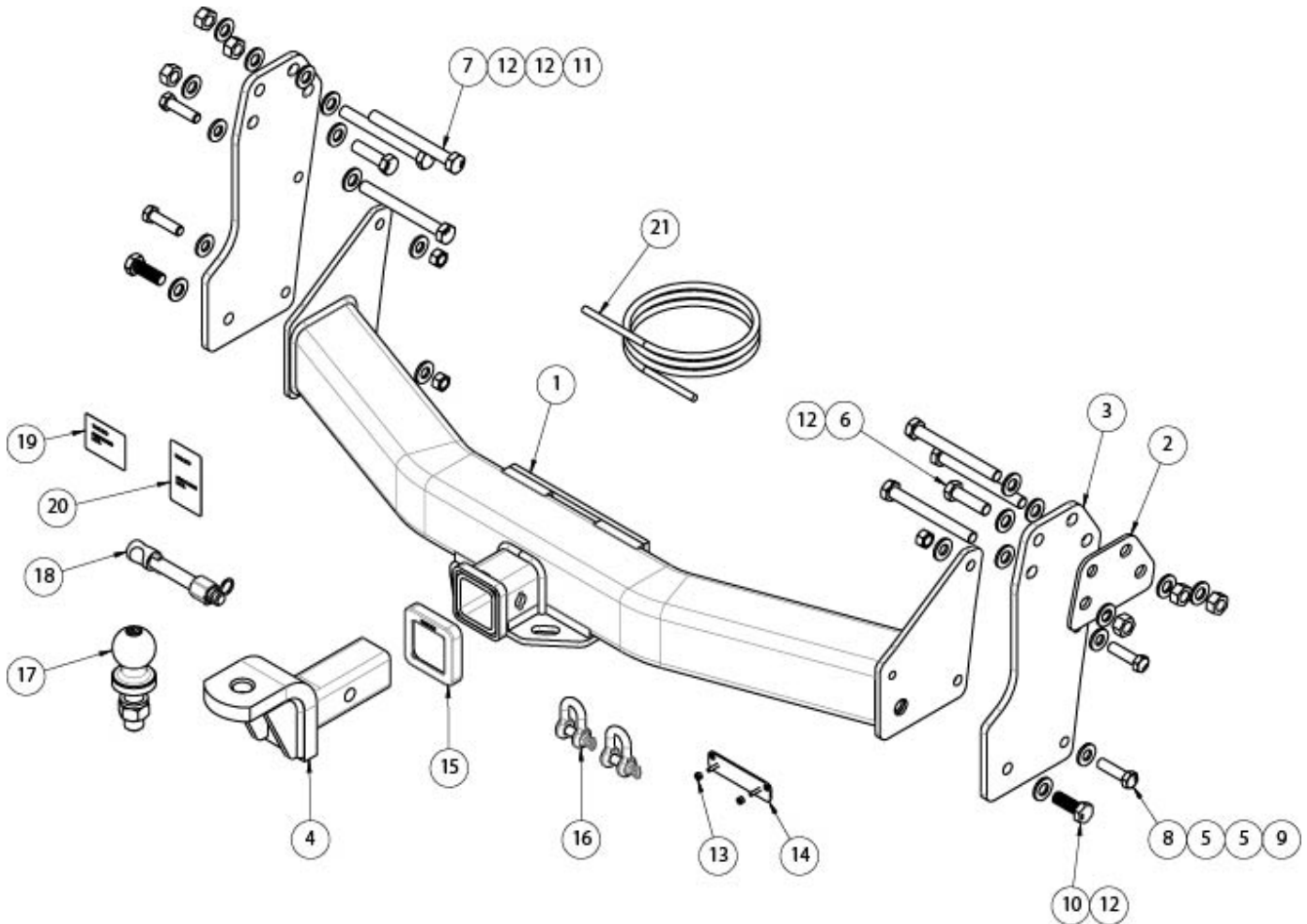

ITEM	DESCRIPTION	QTY
1	CROSSTUBE ASSY	1
2	SPACER PLATE RH	1
3	SIDE ARM	2
4	TRAILER BALL MOUNT	1
5	WASHER PLAIN M12x27x3.0mm	8
6	SCREW HEX HD M14x50x1.5P G10.9	2
7	BOLT HEX HD M14x130x2.0P G10.9	6
8	SCREW HEX HD M12x45x1.25P G10.9	4
9	NUT HEX HD M12x1.25P G10	4
10	SCREW HEX HD M14x40x2.0P G8.8	2

ITEM	DESCRIPTION	QTY
12	WASHER PLAIN M14x28x3.0mm	16
13	NUT NYLOC HEX HD M4x0.7P G8	2
14	PLUG BRACKET	1
15	HITCH BOX COLLAR COVER	1
16	D-SHACKLE 10mm	2
17	TOWBALL 50mm	1
18	SMART PIN SILVER	1
19	COMPLIANCE LABEL	1
20	LOAD RATING LABEL	1
21	WIRING LOOM	1

1. Under bumper on LH side, remove the plug bracket secured with 2 x bolts.
2. Disconnect the socket harness from the vehicle 16-way connector and discard.

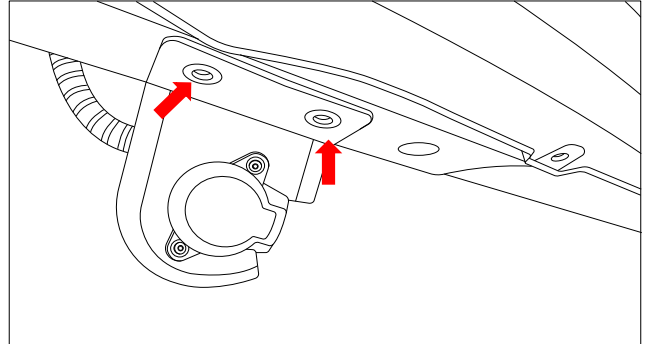

3. Under vehicle, on the inside of the RH chassis rail, remove and discard the 4x bolts securing the bumper to chassis rail.
4. Position the side arm along with the RH Spacer plate to the bumper bracket and loosely secure to the chassis with 1x M14x1.5x50 Gr10.9 bolt complete with 1x washer and 3x M14x2x130 Gr10.9 bolts complete with 2x washers and 1x M14 nut per bolt.

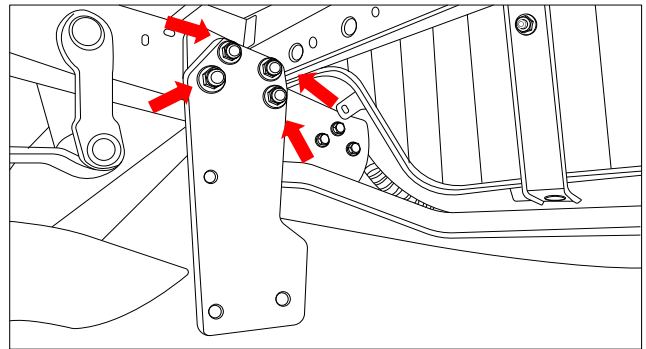

Repeat for the other side, no spacer is required.

**NOTE. Ensure the correct M14x1.5x50 Gr10.9 bolt is being used to prevent stripping the chassis weld nut.**

5. Lift crosstube up to the side arms and loosely secure each side with 2x M12x45x1.25 Gr10.9 bolts complete with 2x washers and 1x M12 nut per bolt and 1x M14x2x40 Gr8.8 bolt complete with 1x washer.

Position the bumper along with the towbar assembly and tighten all fasteners to the following torque:

<b>M12x1.25</b>	<b>Gr10.9</b>	<b>: 125Nm</b>
<b>M14x2</b>	<b>Gr8.8</b>	<b>: 124Nm</b>
<b>M14x1.5</b>	<b>Gr10.90</b>	<b>: 196Nm</b>
<b>M14x2</b>	<b>Gr10.9</b>	<b>: 175Nm</b>

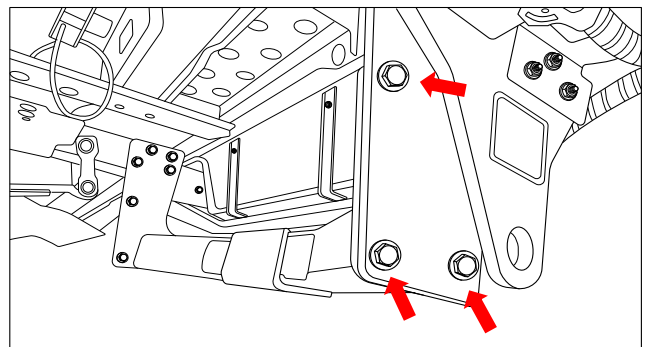

6. For the plug bracket.  
On the underside of the bumper, determine an appropriate position, mark out and drill 2x  $\varnothing 5\text{mm}$  holes 69mm apart on bumper skin to support plug bracket.

Image shown for positional reference.

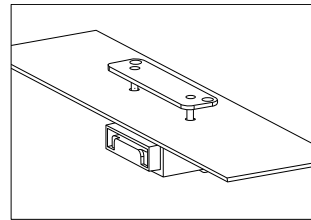
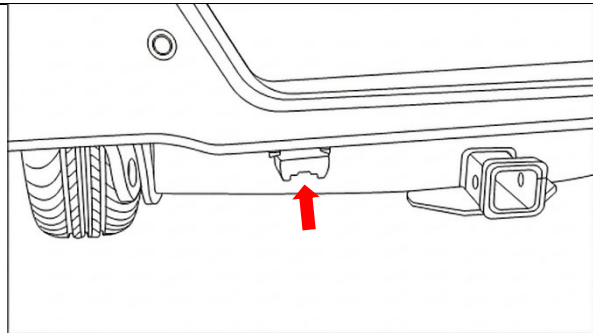

7. For ease of fitment prepare the trailer patch (107093-WL) and tail harness (04943) prior to mounting on the vehicle.
8. Connect the tail harness (1) to trailer patch harness (2).
9. Join the tail harness GREY and GREY/BLACK wires (3) to trailer patch matching GREY and GREY/BLACK wires (4), cover the wires with adhesive heat shrink.

**Apply silicone grease (not supplied) (5) to waterproof the connectors.**

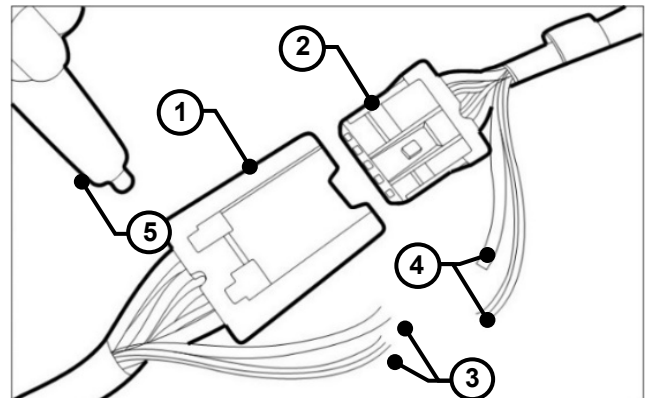

10. Secure trailer socket to plug bracket.
11. Route the trailer patch along the towbar cross tube towards the vehicle 16-way prewire connector.

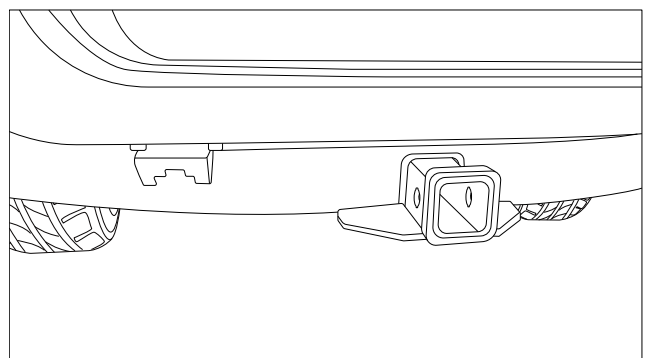

- 
12. Connect the trailer patch to 16-way prewire vehicle connector.
  13. Secure excess harness using cable ties.

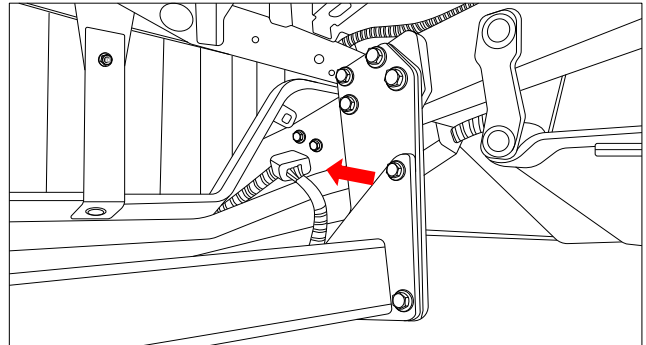

- 
14. Test the trailer patch function using a light board.
  15. Secure excess harness using cable ties ensure to keep away from any sharp edges or moving parts.
  16. Place fitting instructions in glovebox after fitment.



## CUSTOMER INFORMATION

PLACE THESE INSTRUCTIONS IN THE VEHICLE'S GLOVEBOX AFTER INSTALLATION

**THANK YOU FOR PURCHASING TRAILBOSS. WITH CORRECT MAINTENANCE AND CARE THIS PRODUCT WILL PROVIDE A LIFETIME OF TROUBLE-FREE OPERATION.**

### TOWBAR MAINTENANCE AND CARE:

1. Trailboss recommend that the towbar LUG or TBM (Trailer Ball Mount) Pull Pin and R-clip are removed and stored when not in use. Removal of LUG or TBM (Trailer Ball Mount) is advisable when not in use to assist with any of the following.
  - Ensure rear number plate is not obscured.
  - Allow maximum available departure angle and prevent any potential interference.
  - Prevent possible interference with vehicles reverse sensors or camera detecting a tow ball mount as an obstruction during reversing.
  - Removes towball mount as an obstruction for when moving around the rear of the vehicle.
2. Trailboss recommends routine inspection of your towbar to ensure trouble free towing.
  - Bolt security and tension should be regularly inspected and checked for correct tension. Replace any worn or defective parts with suitable grade & class fasteners. Inspection should be requested to coincide with vehicle major services.
3. It is the owner's responsibility to ensure towing and down ball weight capacities of the towing vehicle are not exceeded.
  - Towing and down ball weights allowable may differ according to model variations. Please refer to owner's manual or vehicle dealer to confirm exact rating for your vehicle model variant.
  - It is not uncommon for the vehicle tow rating to differ from the towbar rating. When this occurs, the lesser rating must be adhered to.
  - For vehicles fitted with enhanced vehicle functions that may be altered/changed when towing i.e Trailer sway mitigation, blind spot detection, adaptive cruise control etc. Please consult owner's manual to understand changes enabled when towing and after towing.

### WARRANTY INFORMATION:

Trailboss Towbars are covered by a Lifetime Warranty.

Our goods come with guarantees that cannot be excluded under the Australian Consumer Law. You are entitled to a replacement or refund for a major failure and for compensation for any other reasonably foreseeable loss or damage. You are also entitled to have the goods repaired or replaced if the goods fail to be of acceptable quality and the failure does not amount to a major failure.

For further details please contact customer service on 1800 812 017.

## PRO SERIES SILENT ANTI-RATTLE HITCH PIN

Your Trailboss towbar is equipped with a Pro Series Silent Anti-Rattle Hitch Pin technology to help reduce towbar tongue rattle in most driving conditions. Please ensure below instructions are understood and routine maintenance is carried out to ensure best towing experience.

Regularly inspect for wear and check the tightness of the Silent Anti-Rattle Hitch Pin. Follow instructions below to re-tighten the nut as necessary when movement and noise in the tow ball mount is noted.

- Before towing, ensure R-Clip is properly installed and hitch pin nut is installed and tensioned. Replacement parts are available from your Pro Series Distributor.

## TOWBALL MOUNT REMOVAL/INSTALLATION

### STEP 1

Insert Trailer Ball Mount (TBM) (a) into towbar hitchbox (b), aligning hole in TBM shank (c) with hole in hitchbox (d) (Fig. 1)

### STEP 2

Insert Silent Anti-Rattle Hitch Pin (e) through hole in hitchbox and hole in TBM shank (g); ensure the locators are inserted into the notches in the hitchbox (Fig. 2)

### STEP 3

Screw Silent Anti-Rattle Hitch Pin Nut (f) onto Smart Pin (g); tighten Smart Pin Nut until finger tight, ensuring TBM is restrained from up and down movement.

### STEP 4

Tighten Silent Anti-Rattle Hitch Pin Nut by turning nut a further 1/8th of a turn in the clockwise direction using a 24mm spanner (Fig. 4).

### STEP 5

Install Silent Anti-Rattle Hitch Pin R-Clip through the hole that provides best clearance or easiest access. (Fig. 5)

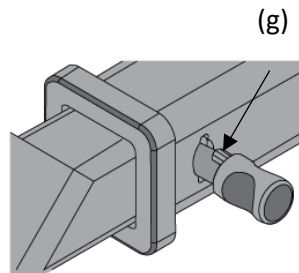
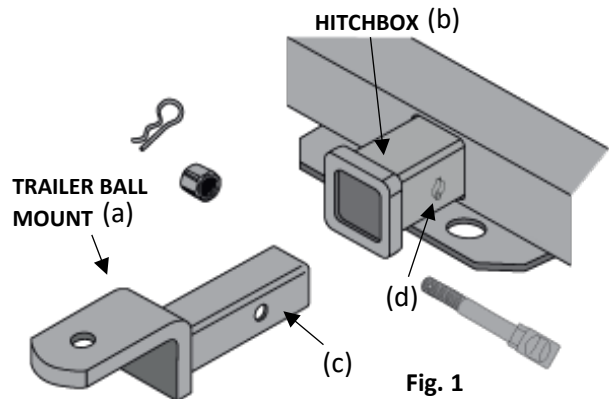

Fig. 2

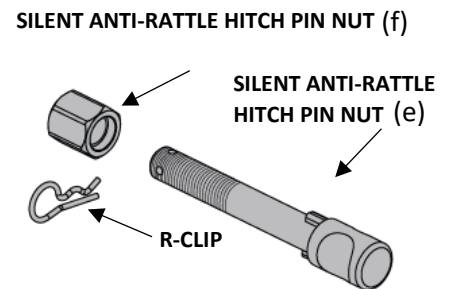

Fig. 3

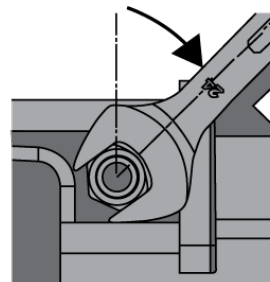

Fig. 4

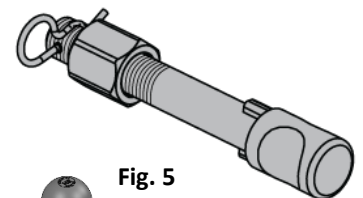

Fig. 5

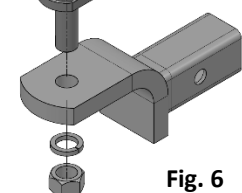

Fig. 6