



Towbar Fitting Instructions  
To Suit **PEUGEOT PARTNER 2012**  
Part Number **PG17L**  
Rating **1000/100 kg**

PLACE THESE INSTRUCTIONS IN THE VEHICLE'S GLOVEBOX AFTER INSTALLATION IS COMPLETE

**WARNING:**

1. Do not, drill, cut, weld or otherwise modify the tow bar.
2. If you are using electric welding on a motor vehicle, **always** check that the vehicle is not equipped with electronic engine or instrument management equipment. Failure to do so could **destroy** any onboard computers. If in doubt, check with the vehicle's manufacturer.
3. The high tensile fasteners supplied with this product were used to achieve the specified rating. If replacement is required ensure that fasteners of the same rating & quality are used. Contact an authorised **Trailboss** dealer if further information is required.

**General:**

1. Ensure all hardware items have been included refer to assembly diagram.
2. It is recommended that the instructions are read through and completely understood before making any attempt to fit this product.
3. Be wary of any changes to vehicle designs or other accessories that may conflict with the installation of this product.
4. Before drilling ensure that the area is clear of fuel, electrical & other components.
5. All holes drilled into the body panels shall have all burrs & swarf removed then coated with a suitable rust preventative paint.
6. For vehicles that require the bumper to be cut. Ensure cut out area is in correct position on the vehicle prior to cutting the bumper.
7. The high tensile fasteners supplied with this product were used to achieve the specified rating. If replacement is required ensure that fasteners of the same rating & quality are used. Contact an authorized **Trailboss** dealer if further information is required.
8. Ensure that all hardware is fastened to torque list below check fasteners on regular basis.
9. Tow bar load rating sticker provided with this product shall be conspicuously located on inside rear end of the driver's door. **(See diagram below)**.
10. Trailboss recommends that you check your tow ball to ensure that it complies with the Australian standards **AS 4177.2**.
11. **PLEASE NOTE:** It is advised to remove your lug or tbn when not actually towing so as to produce a clear view of the vehicles registration plate if obscured, and to also provide maximum available departure angle
12. Pull Pin must be fit in down position.

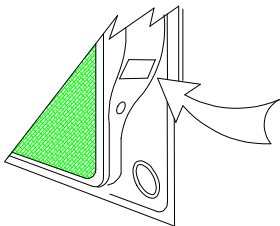

Place load rating sticker  
inside driver's door here

**FOR TRAILER TOWING PURPOSES ONLY**  
For towing capacity details please refer to vehicle owner's manual or to the manufacturer. Overloading can void your warranties.

**RECOMMENDED ASSEMBLY TORQUE LISTING**

Diameter	Grade 8.8 Bolt
M6	9.5 Nm
M8	21.7 Nm
M10	43.4 Nm
M12	77.3Nm
M14	146 Nm
M16	189.8 Nm

**Tow bar Maintenance and Care.**

Trailboss recommends that bolt torque's, as listed below, are routinely and regularly inspected and checked for correct tension. Replace any worn or defective parts.

We recommended to remove Tow Ball Mounts (TBM's, tongues or lugs) when not being used for any considerable length of time.

So as to avoid injury, when not towing it is suggested that the tongue, Pull Pin and R-clip are removed then stored in a safe, clean and dry place, away from excessive moisture.

Hitch Pull Pins and spring "R" clips are regularly checked for proper installation. Replace any worn or defective parts.

# TRAILBOSS

Towbar Fitting Instructions  
To Suit **PEUGEOT PARTNER 2012**  
Part Number **PG17L**  
Rating **1000/100 kg**

PLACE THESE INSTRUCTIONS IN THE VEHICLE'S GLOVEBOX AFTER INSTALLATION IS COMPLETE

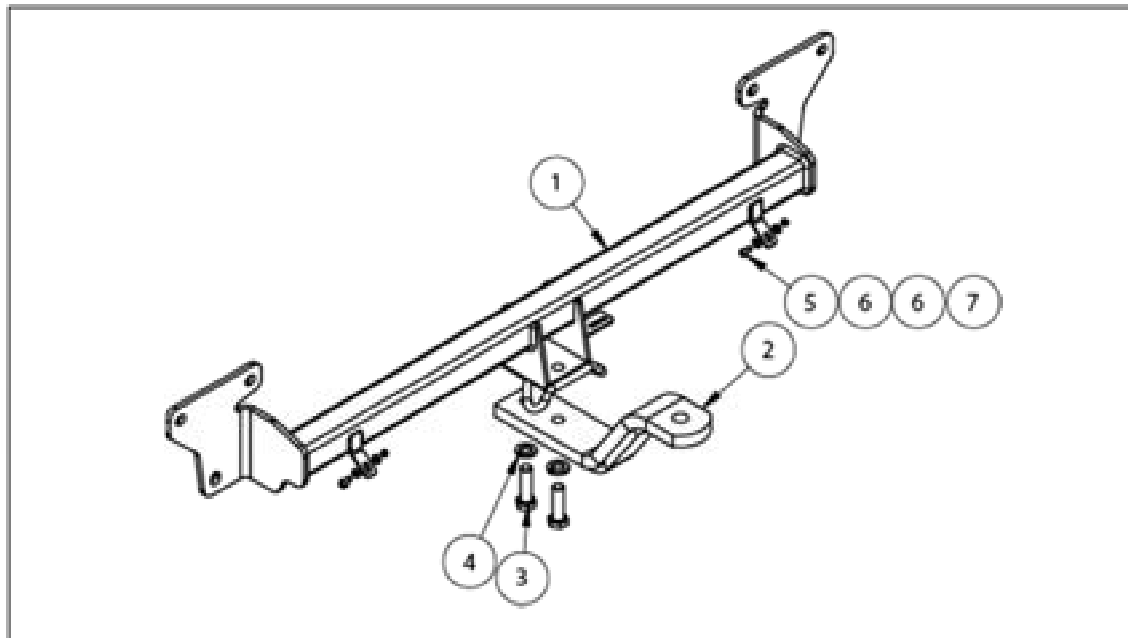

QTY	DESCRIPTION	ITEM NO
1	WELDED ASSEMBLY	1
1	LUG ASSEMBLY	2
2	CS M16x55 BOLT	3
2	M16x5x3.5 SPRING WASHER	4
2	SET SCREW HEX HD M5x20x0.8P	5
4	WASHER FLAT M6x12.5x1.2	6
2	NUT NYLOC M5-0.8 Z/P	7

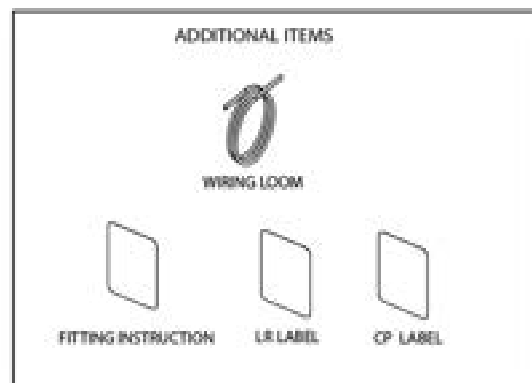



Towbar Fitting Instructions  
To Suit **PEUGEOT PARTNER 2012**  
Part Number **PG17L**  
Rating **1000/100 kg**

PLACE THESE INSTRUCTIONS IN THE VEHICLE'S GLOVEBOX AFTER INSTALLATION IS COMPLETE

**INSTRUCTION:**

1. Open rear door and remove four torx head screws from underneath trim.
2. Remove two torx head screws from each side of the bumper.
3. Remove one scrivet from inside each wheel arch.
4. Remove one scrivet underneath each side of the bumper.
5. Remove two screws from underneath of the bumper center.
6. Pull sides of bumper outwards and dislodge bumper. Place in a safe place.
7. Remove six M12 bolts fastening the Impact Beam to the chassis panel. Discard Impact Beam and retain all fasteners.
8. Apply towbar to vehicle, aligning the holes on the towbar with the six impact beam mounting holes.
9. Loosely fasten towbar with the six M12 fasteners retained from step 7.
10. Fasten all bolts to torque specifications listed on page 1.
11. Reattach Bumper using steps 1-7 in reverse, using M5 fasteners supplied to attach bumper to towbar.



Wiring Loom Fitting Instructions  
To Suit Peugeot Partner  
Part Number 100852-WL

## Wiring Loom Installation Instructions

Peugeot Partner  
Part No: 100852-WL  
ECU Required: 04831

Tail Harness Length Required: 1800mm

Wiring Loom Installation Time: Approx 30 Mins

## Wiring Loom Fitting Instructions To Suit Peugeot Partner Part Number 100852-WL

1. In the cargo hold, remove the LHS 'D' pillar trim panel.

**Repeat for the RHS.**

2. On the LHS of the vehicle cargo hold, remove the side door trim by first removing the two screws.
3. Remove the LHS cargo hold compartment trim above the wheel arch.
4. On the LHS of the vehicle, remove the lower 'B' pillar trim above the wheel arch.
5. On the LHS of the passenger's footwell, remove the kick panel trim by first removing the fastener.
6. Inside the glove box compartment, remove the fuse panel cover.
7. On the LHS of the rear wheel arch, near the air vent **(1)**, drill out a hole to Ø30mm **(2)**.

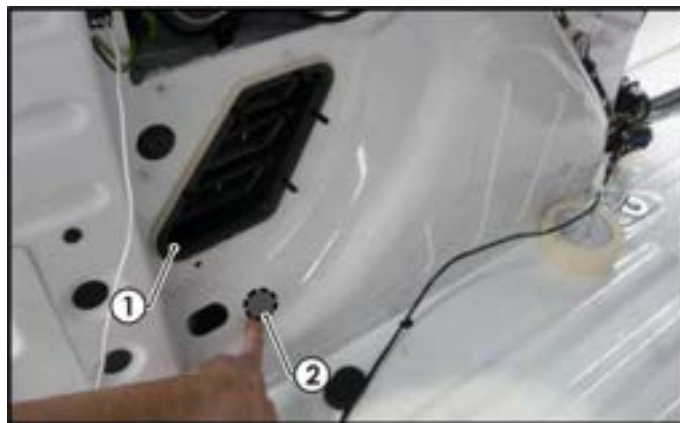

8. On the RHS, dislodge the tail light cover, and disconnect the tail light connectors. Connect the trailer patch (100852-WL) connectors in between.
9. Route the trailer harness up along the inside of the 'D' pillar and across towards the LHS tail light.
10. On the LHS of the vehicle, dislodge the tail light cover and disconnect the tail light connectors. Connect the trailer patch connectors in between.
11. Route the trailer patch through the 'D' pillar towards the LHS cargo hold cavity.
12. Connect the trailer patch ground ring terminal to the vehicle grounding point.
13. Apply double sided tape to the ECU (04831) and adhere it to the vehicle sheet metal on the LHS of the cargo hold cavity in a suitable location.
14. Connect the trailer patch 12-way connector to the ECU.

## Wiring Loom Fitting Instructions To Suit Peugeot Partner Part Number 100852-WL

15. Route the 'ORANGE' power wire along the existing vehicle harness towards the front of the vehicle.
16. Secure the 'ORANGE' power wire to the existing vehicle harness using cable ties (not supplied).
17. Continue routing the 'ORANGE' power wire towards the front of the vehicle past the 'B' pillar.
18. Continue routing the 'ORANGE' power wire up the kick panel area towards the fuse panel.
19. Inside the fuse panel, locate the 20-amp fuse **(1)** as shown and discard.
20. Insert the supplied 20-amp fuse **(2)** into the upper slot of the add-a-fuse **(4)** and insert the supplied 30-amp fuse **(3)** into the bottom slot of the add-a-fuse **(4)**.
21. Plug the add-a-fuse **(4)** into the previously removed 20-amp fuse slot **(1)**.
22. Connect the power patch 1-way connector **(5)** into the add-a-fuse harness mating connector **(6)**.

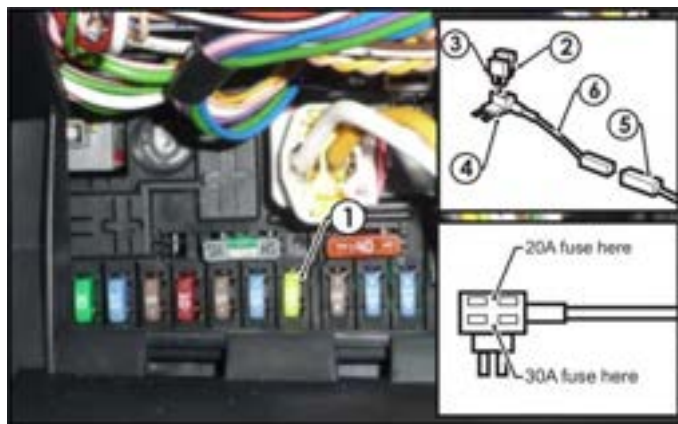

23. Mount the trailer socket to the tow bar mounting bracket using M4 fasteners (not supplied).
24. Route the tail harness across the tow bar towards the LHS of the vehicle and up through the previously drilled out hole.
25. Ensure the tail harness grommet is seated correctly and secure in place using a cable tie (not supplied).
26. Connect the tail harness (tail length 1200mm) 8-way connector to the trailer patch mating 8-way connector.



Wiring Loom Fitting Instructions  
To Suit Peugeot Partner  
Part Number 100852-WL

27. Test the trailer patch function using a light board or multi meter.
28. Secure all harnesses using cable ties (not supplied).
29. Re-fit all removed parts and secure all fasteners, ensuring there are no squeaks or rattles.
30. Place the fitting instructions in the glove box after fitment.