

**PRODUCT DETAILS:**

---

|                                      |         |                                  |      |    |
|--------------------------------------|---------|----------------------------------|------|----|
| <b>Part Number:</b>                  | MA92L   | <b>Maximum Towing Braked:</b>    | 1200 | kg |
| <b>ECU Number:</b>                   | 04836   | <b>Maximum Towing Unbraked:</b>  | 640  | kg |
| <b>Tail Harness Length Required:</b> | 1800 mm | <b>Maximum Static Ball Load:</b> | 50   | kg |
| <b>TBM/Lug Part Number:</b>          | 07756   |                                  |      |    |

---

**FITTING DETAILS:**

---

|                                  |           |                           |     |
|----------------------------------|-----------|---------------------------|-----|
| <b>Towbar Installation Time:</b> | 95 Mins.  | <b>RPA Disable/Other:</b> | YES |
| <b>Total Installation Time:</b>  | 180 Mins. |                           |     |
| <b>Bumper Cut Required:</b>      | No        |                           |     |

---

**Note:**

- Use tail 04944 to disable smart city brake support (SCBS) when towing.

### TRAILBOSS RECOMMENDS THAT INSTRUCTIONS ARE READ AND UNDERSTOOD COMPLETELY PRIOR TO FITMENT.

#### BEFORE YOU START:

Check all hardware items have been included refer to assembly diagram.  
Please ensure this towbar is only fitted to vehicle models as per Trailboss application guide.

#### Bumper Cuts

Vehicle and bumper variations can and do occur during vehicle manufacture after initial towbar design. Fitment of towbar to vehicle and accuracy of bumper cut must be assessed prior to any bumper modifications made. Incorrect bumper cuts are not covered under Trailboss warranty.

**NOTE: Bumper cuts need to be approached with care, refer to notes below.**

- Bumper centreline – where the centreline of the bumper needs to be determined, the installer must assess centre point by measurement of bumper width or determining two symmetrical reference points to give centreline.
- Bumper edge – To assist with accurate bumper cut measurement, reference to the start of the bumper edge is now being commonly used.
  - Measure from bottom edge along bumper and around corner to the 70 mm point (Figure 1).
  - Do not measure from visible bumper front of corner, upwards (Figure 2).

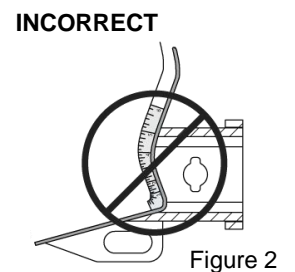
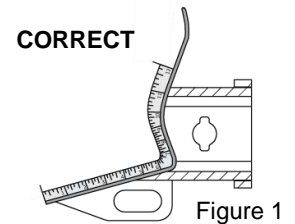

#### Drilling

- For any required drilling during installation, ensure that the area is clear of fuel, electrical & other components that may be damaged.
- All holes drilled into metal body panels shall have all burrs & swarf removed then coated with a suitable rust preventative paint.

#### Bolts/Fasteners

- Ensure that all hardware is fastened to correct torque as specified in this fitting instruction.
- All fasteners supplied with this product are used to achieve a specified clamp loading. If replacement is required ensure that fasteners of the same grade and class are used.

**NOTE: Achieving correct torque is critical to proper installation and responsibility of the installer. Towbar failures attributed to tension issues from over tightening or under tightening are not covered by Trailboss warranty.**

#### Product Labels

- a. Towbar load rating sticker provided with this product shall be conspicuously located on inside rear end of the driver's door.

#### WARNING:

**Do not, drill, cut, weld or otherwise modify the towbar.**

**FOR TOWING PURPOSES ONLY - This towbar is designed and tested by Trailboss to adhere to ADR 62/02 which provides only for the expected load demands of towing.**

### TOWBAR ASSEMBLY DIAGRAM

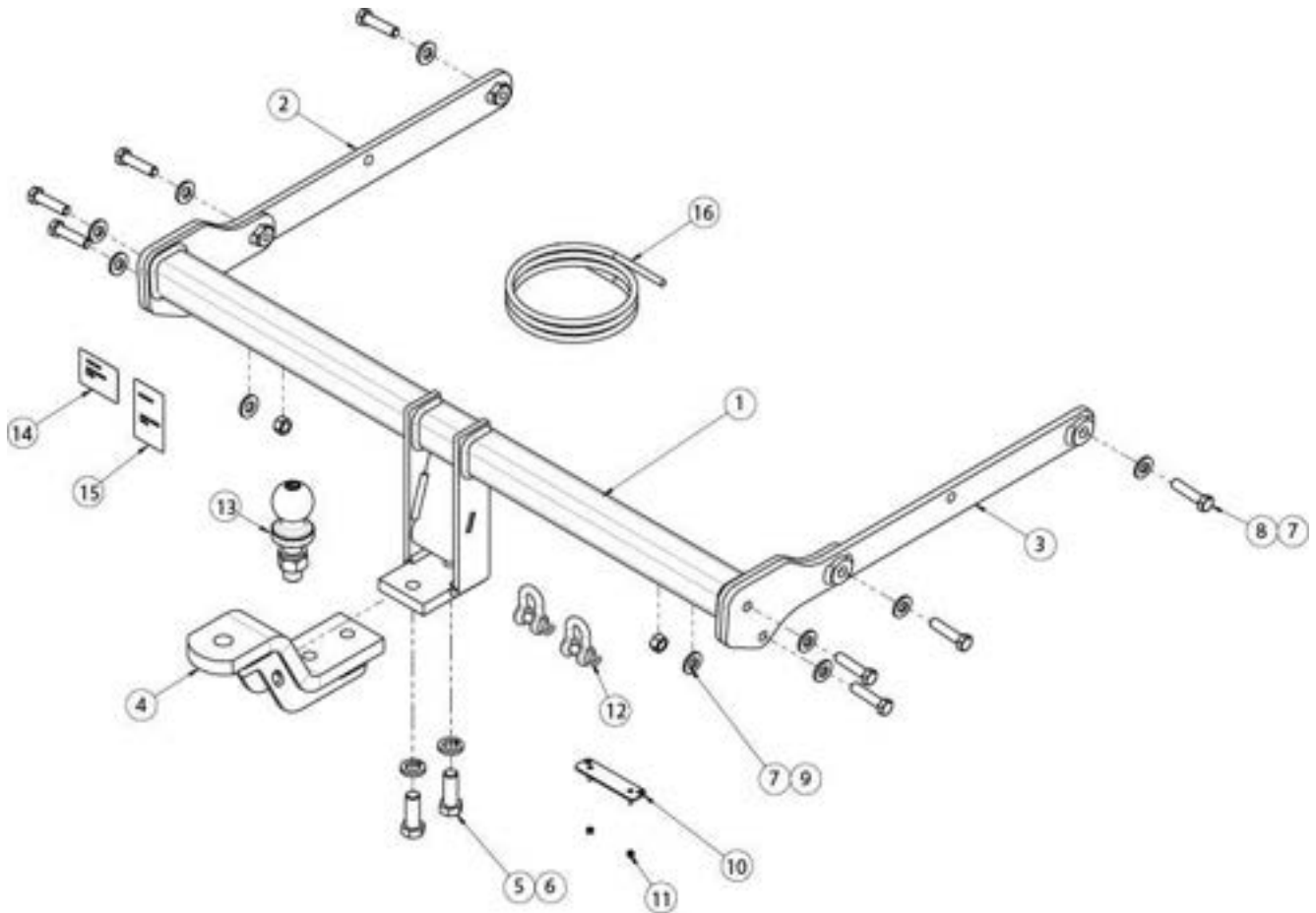

| ITEM | DESCRIPTION              | QTY |
|------|--------------------------|-----|
| 1    | WELDED ASSEMBLY          | 1   |
| 2    | LH SIDEARM               | 1   |
| 3    | RH SIDEARM               | 1   |
| 4    | LUG ASSEMBLY             | 1   |
| 5    | BOLT HEX HD M16x45x2.0P  | 2   |
| 6    | SPRING WASHER M16x5x3.5  | 2   |
| 7    | WASHER PLAIN M14x28x3    | 10  |
| 8    | BOLT HEX HD M12x50x1.75P | 8   |

| ITEM | DESCRIPTION              | QTY |
|------|--------------------------|-----|
| 9    | NUT HEX HD M12x1.75P     | 2   |
| 10   | PLUG BRACKET             | 1   |
| 11   | NUT NYLOC HEX HD M4x0.7P | 2   |
| 12   | "D" SHACKLE 10mm         | 2   |
| 13   | TOWBALL 50mm             | 1   |
| 14   | COMPLIANCE LABEL         | 1   |
| 15   | LOAD RATING LABEL        | 1   |
| 16   | WIRING LOOM              | 1   |

- 
1. Release tailgate to expose boot cabin.

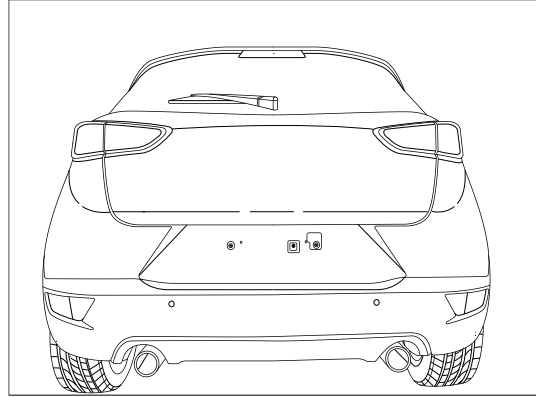

- 
2. Remove 4 x Screws on both Passenger and Drivers side. Where 2 x Screws secure the tail light and a further 2 x Screws secure the bumper to the vehicle.

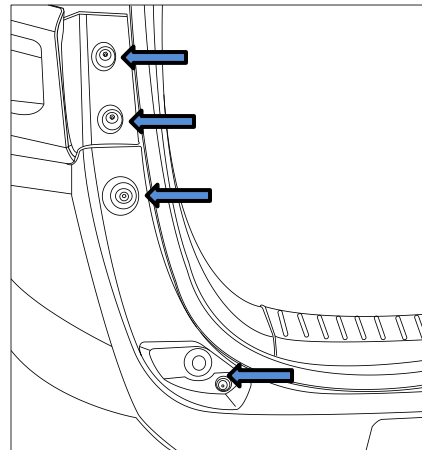

- 
3. Carefully remove tail light and disconnect wiring loom. Repeat for Passenger and Driver side.

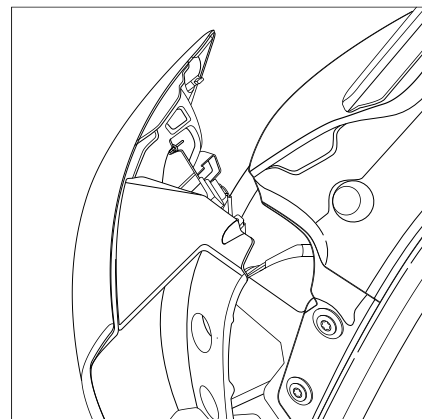

- 
4. On the underside of the vehicle remove 2 x Screws where the bumper joins with the guard liner. Repeat for Passenger and Driver side.

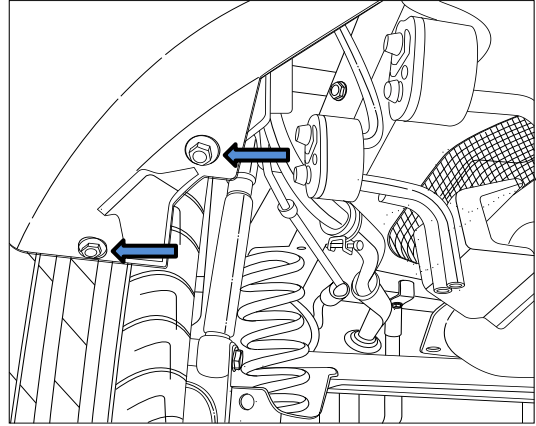

- 
5. Remove 4 x trim clips on the underside of the bumper. Detach the plastic centre garnish from the bumper.

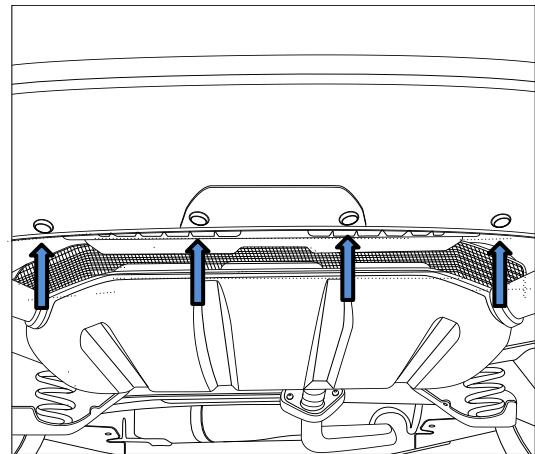

- 
6. Remove 2 x Torx screws on the centre of the bumper where the licence plate holder is located.

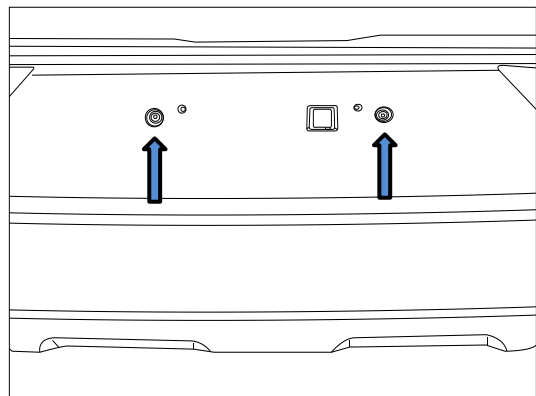

- 
7. On the inside of the guard liner remove 6 x Trim Clips and 2 x Screws. Repeat for Passenger and Driver side.

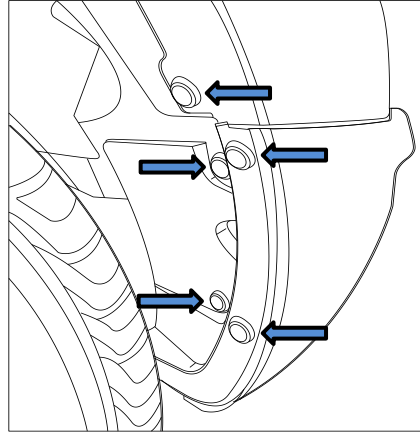

- 
8. On the underside of the guard moulding remove the male trim clip located above of the centre of the wheel. Repeat for Passenger and Driver side.

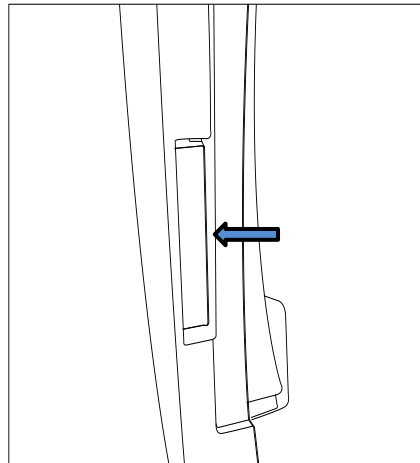

- 
9. On the underside of the guard moulding remove the second male trim clip located rear of the centre of the wheel. Repeat for Passenger and Driver side.

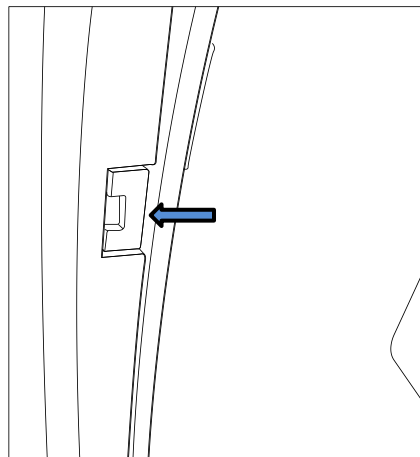

- 
10. Carefully remove the outer guard moulding. Then remove 1 x trim Clip and 1 x Set Screw securing the bumper to the reinforcement. Repeat for Driver and Passenger side.

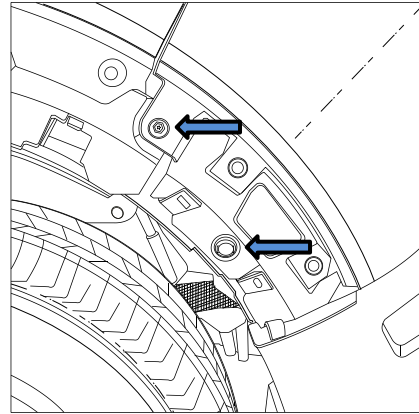

- 
11. Carefully remove the bumper by first peeling away at the sides. Then lift the bumper up to clear the keyway-locking tab to release the bumper. Carefully disconnect any factory fitted reverse parking sensors.

**Note:** It may be easier to remove the bumper by partially detaching the boot seal.

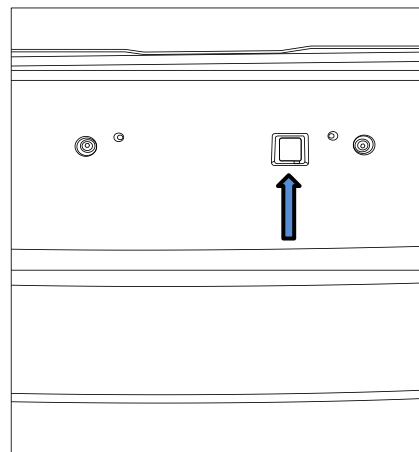

- 
12. Remove 8 x Hex Flange nuts to detach the factory impact beam and discard.

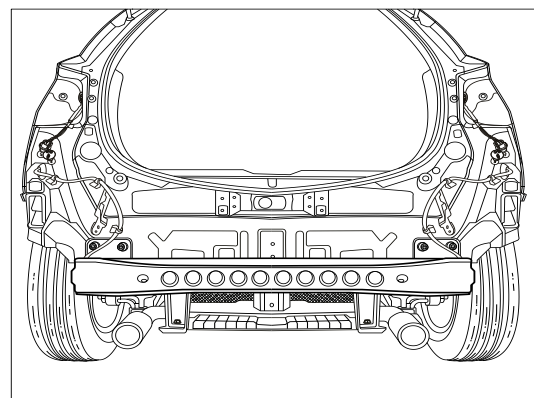

- 
13. Remove and discard the horizontal plastic protector secured with 2 x Trim clips.

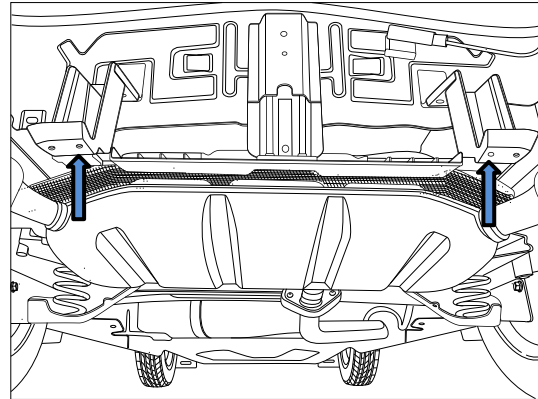

- 
14. Slide Sidearm into the chassis rail.

Repeat for the other side.

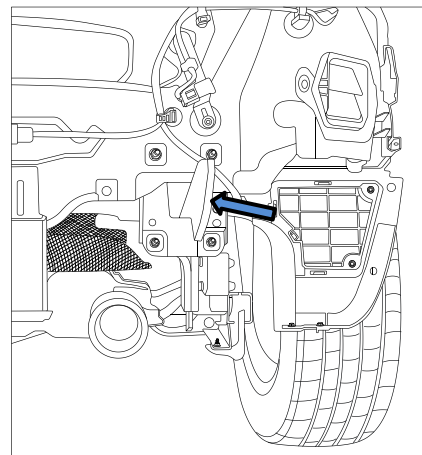

- 
15. Peel off the tape covering the two holes in the chassis rail. Aligning with the holes in the side arm.

Loosely secure side arm using 1 x M12 x 50 x 1.75P Bolts per side.

Repeat for the other side.

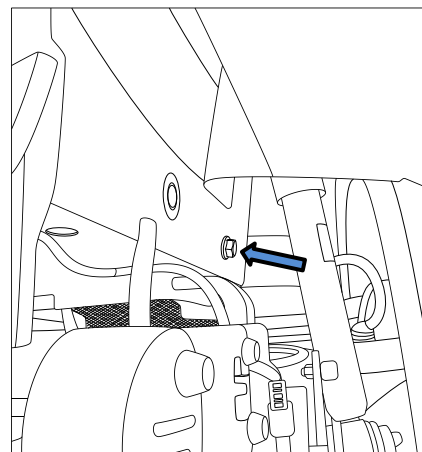

- 
16. Fit the towbar to the side arms and loosely secure using 3 x M12 x 50 x 1.75P Bolts, 4 x M12 Washers and 1 x M12 x 1.75P Nut Per Side

Fit the Lug Assy using 2 x M16 x 45 x 2.0P

**Torque Fasteners Specifications listed below:**

**M12 x 50 x 1.75P Bolt: 77Nm**

**M16 x 45 2.0P Bolt: 197Nm**

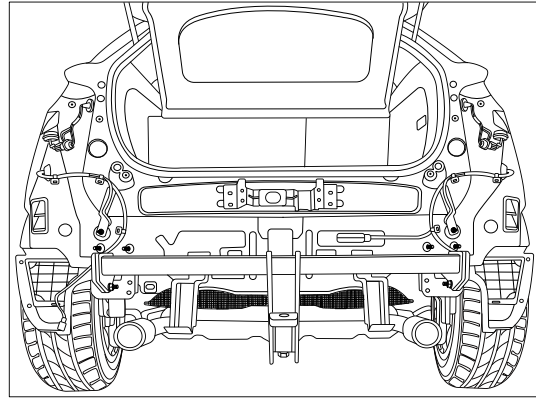

- 
17. Determine an appropriate position for the plug bracket. Mark out and drill 2 x  $\varnothing$ 5mm holes 69mm apart on bumper skin to support plug bracket.

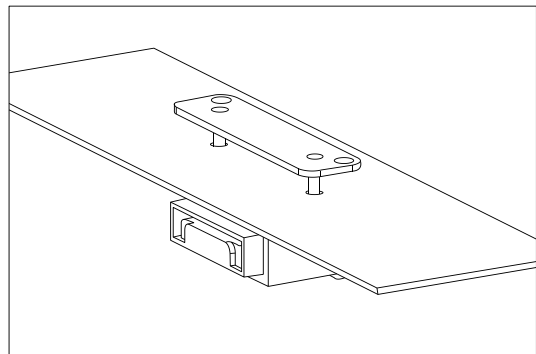

### IMPORTANT

Due to possible vehicle variations, always confirm any noted vehicle colour wires with a multi-meter to ensure the correct function is identified before soldering or scotch locking. For vehicle wires denoted with two colours (example; RED/GREEN) the first colour will always be the main wire colour while the second colour is the thinner trace colour on the wire.

18. Disconnect negative battery terminal.
19. Inside the vehicle cabin, remove the LHS front door sill trim (1).
20. Dislodge the bottom of the LHS front rubber weather seal (2).
21. Remove the kick panel trim (3) by first removing the trimming nut (4).

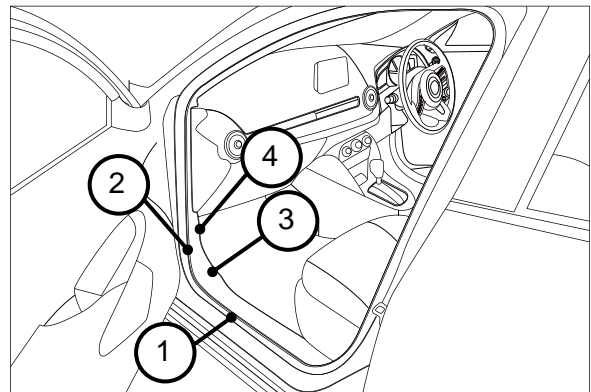

22. Remove the LHS rear door sill trim (1).
23. Dislodge the bottom of the LHS rear rubber weather seal (2).
24. Dislodge the bottom of the LHS 'B' pillar trim (3).
25. Dislodge the bottom of the LHS 'C' pillar trim (4).

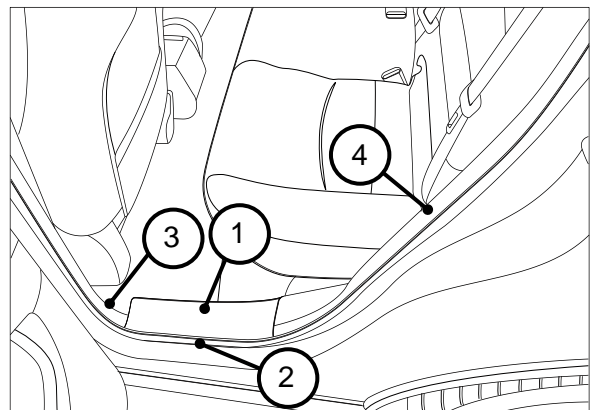

26. Remove the RHS front door sill trim (1).
27. Dislodge the bottom of the RHS front rubber weather seal (2).
28. Remove the kick panel trim (3) by first removing the trimming nut (4).

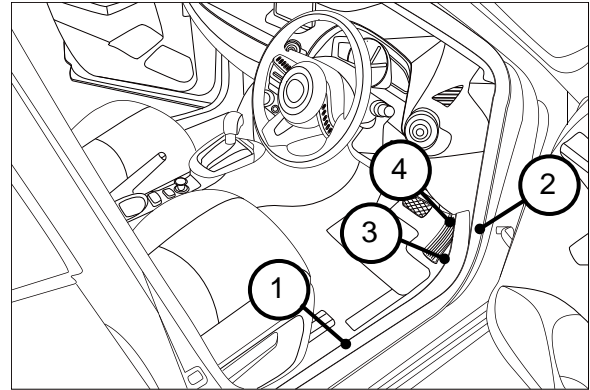

29. Remove the RHS rear door sill trim (1).
30. Dislodge the bottom of the RHS rear rubber weather seal (2).
31. Dislodge the bottom of the RHS 'B' pillar trim (3).
32. Dislodge the bottom of the RHS 'C' pillar trim (4).

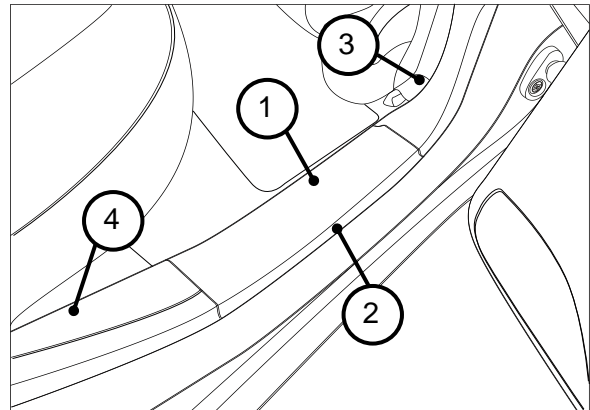

33. In the luggage compartment, remove the parcel shelf (1) and fold the rear seats forwards (2).
34. Remove both the floor cover carpets (3).

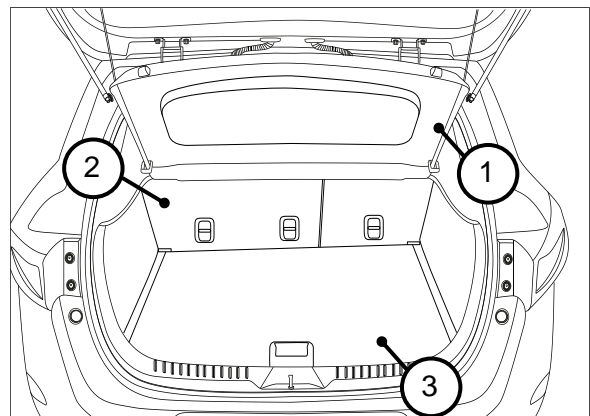

35. Remove the foam inserts (1).

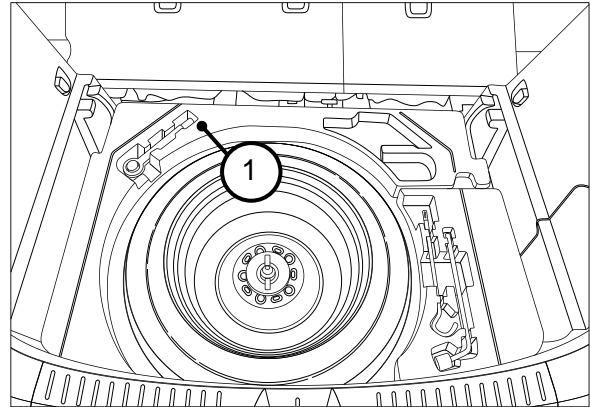

36. On the rear luggage compartment trim (1),  
remove the two clips (2).

37. Remove the rear luggage compartment trim (1)  
by pulling in an upwards direction.

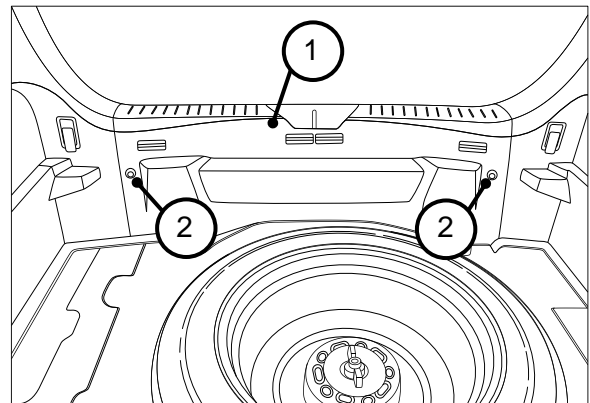

38. On the RHS luggage compartment trim (1)  
remove the clip (2).

39. Remove the RHS cargo hooks (3) by first  
removing the 10mm bolt (4).

40. Dislodge the RHS luggage compartment trim (1)  
and disconnect the light connector (5).

41. Remove the RHS luggage compartment trim (1).

**Repeat for the LHS.**

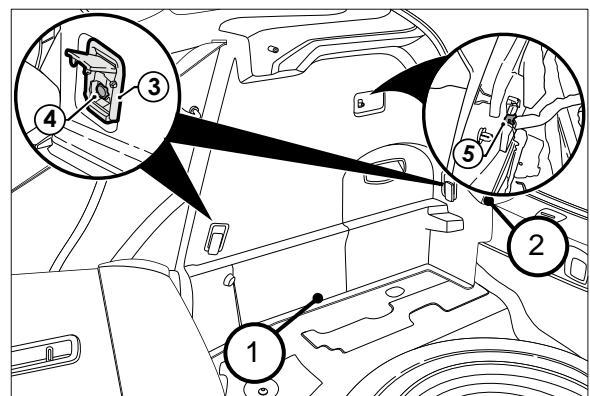

42. Connect the Trailer Wiring Harness ECU 12-way connector (1) to the ECU (04836) (2).
43. Clean the back of the ECU (2) and the area on the sheet metal (3) where the ECU (2) will be mounted.
44. Secure the ECU (2) to the previously cleaned surface.

**Always ensure the ECU is mounted with the 12-way connector facing downwards to avoid any chance of water ingress or condensation.**

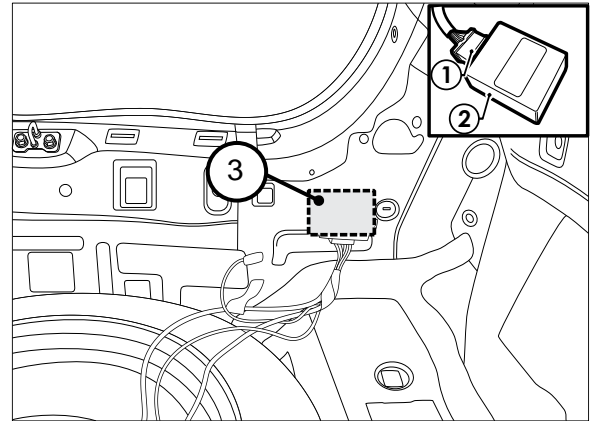

45. Connect the 6-way connectors (1) from the vehicles tail lamp wiring harness, to the 6-way mating connectors (2) on the Trailer Wiring Harness.
46. Secure the Trailer Wiring Harness ground ring terminal (3) to the vehicle earth point using the existing fastener.

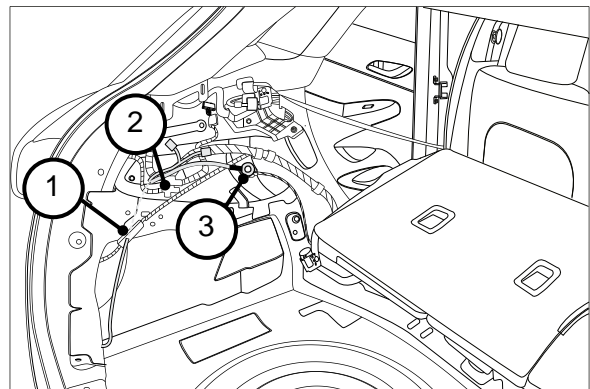

47. Route the Trailer Wiring Harness (1) towards the RHS of the vehicle following existing harness where possible.

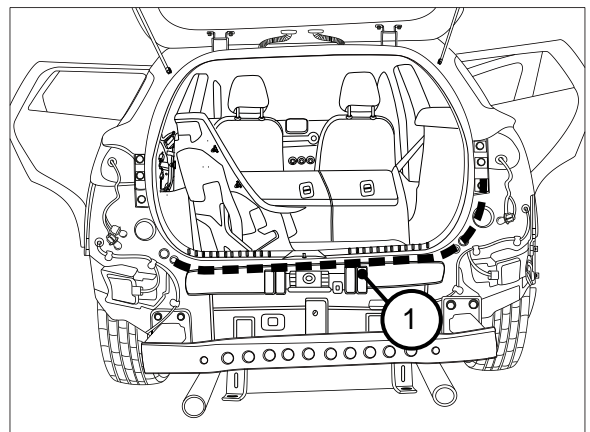

48. On the RHS of the luggage compartment, connect the 6-way connectors (1) from the vehicle's tail lamp wiring harness, to the 6-way connector patch (2) on the Trailer Wiring Harness.

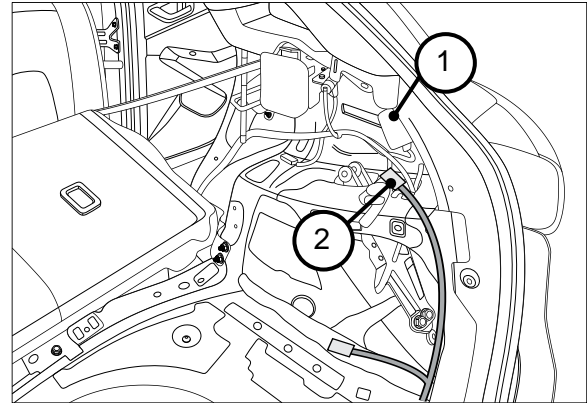

49. In the driver's side footwell, disconnect the RPA module connector and determine if it's a 24-way or 28-way connector.  
 50. For a 28-way connector, patch the RPA Disable patch in between vehicle harness and ECU.  
 51. For a 24-way connector proceed to step 52.

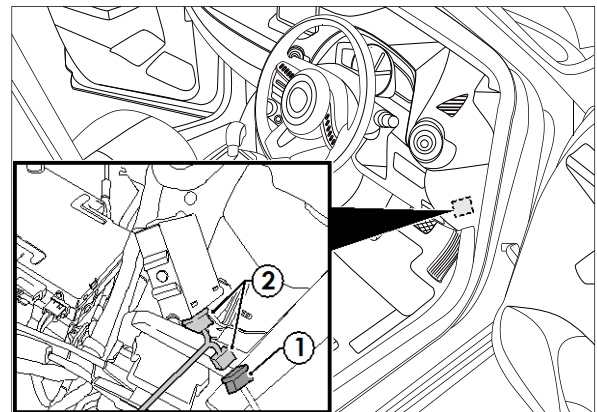

**Note: this step is on for 24-way connector.**

52. Cut the RPA Disable patch 28-way connectors to expose the green wire.  
 53. Locate the RPA module 24-way connector, untape the harness approx. 100mm and locate the vehicle wires pin 7 and 8.  
 54. Cut both wires and solder the connector side pins 7 and 8 wires to the RPA Disable patch green wire.  
 55. The remaining cut wires tape back to the main harness.  
 56. Plug the connector back into the module.

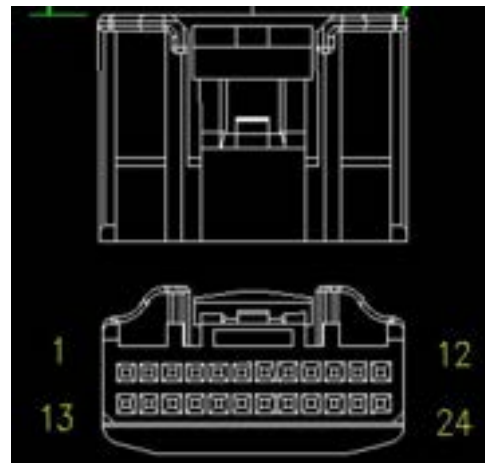

- 
57. Following the main harness on the RHS of the vehicle, route the RPA Disable Patch (1) towards the rear of the vehicle.
58. Secure harness using cable ties. (not supplied)

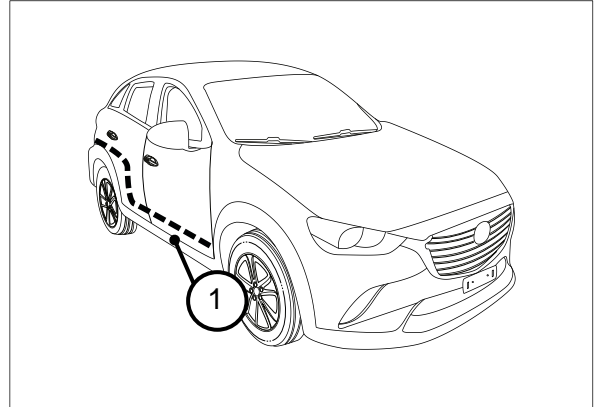

- 
59. Connect the Trailer Wiring Harness 1-way connector (1) to the RPA Disable Patch 1-way mating connector (2).

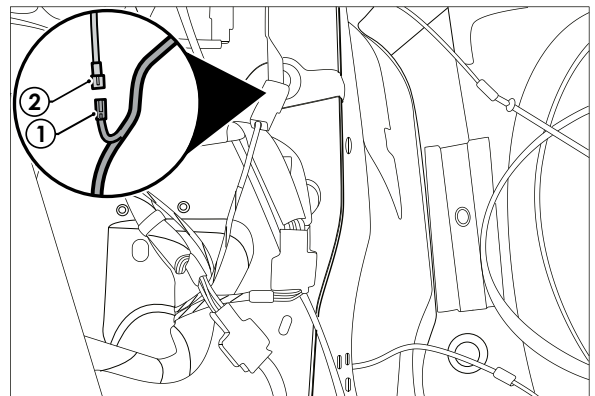

- 
60. From the luggage compartment area, route the Power Line (1) along the vehicle harness where possible, to the fuse panel located in the front passenger side foot well.

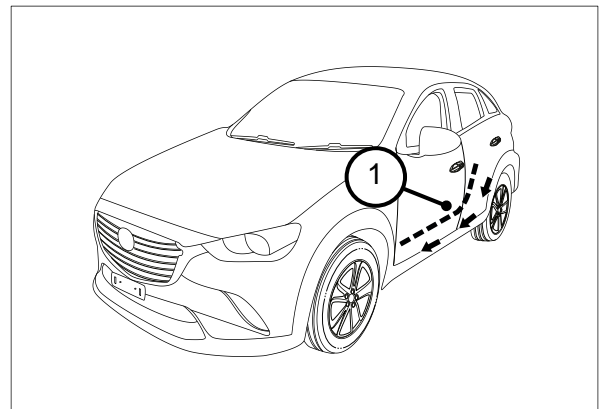

61. Insert the supplied 20A fuse (1) into the upper slot of the add-a-fuse (2).
62. Plug the add-a-fuse (2) into the vacant fuse slot.

**Ensure the add-a-fuse is mounted in the orientation as shown.**

63. Connect the power connector (3) to the add-a-fuse mating connector (4).

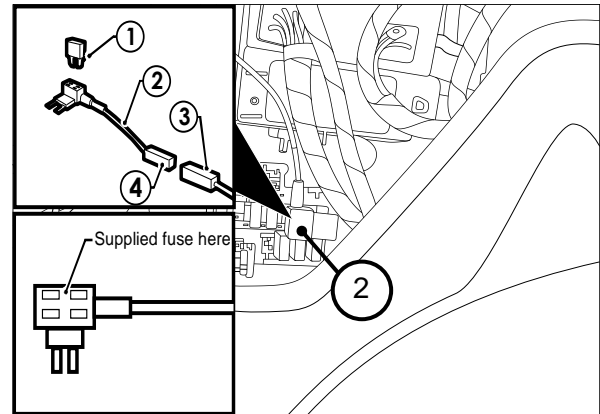

64. Drill grommet hole (1) out to 30mm using a step drill.

**Ensure the interior area being drilled into is clear of any obstructions. Apply rust inhibitor after drilling.**

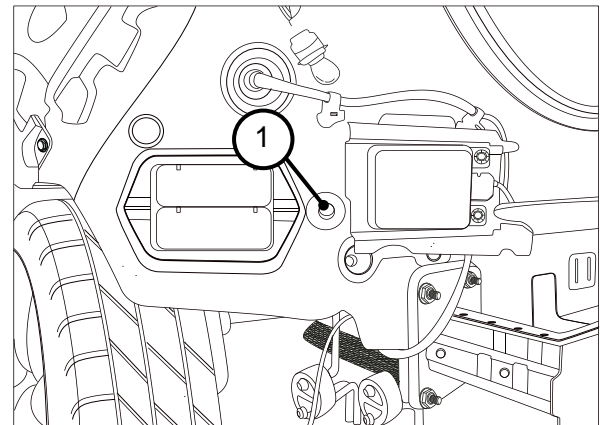

65. At the rear exterior of the vehicle, mount the tail harness socket (1) to the towbar mounting bracket using M4 fasteners (not supplied).
66. Route the tail harness (P/No: 04844) (2) across the LHS and up into the exposed grommet hole (3).
67. Adjust the trailer patch harness grommet so that it is seated correctly and cable tie (not supplied) in place.

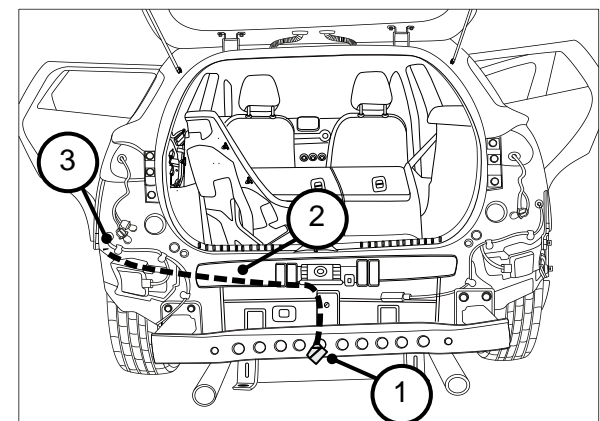

- 
68. Connect the tail harness 8-way connector (1) to the trailer patch 8-way mating connector (2).
  69. Connect wires with crimp, GREY (3) and GREY/BLACK (4) wires to the patch matching GREY (3) and GREY/BLACK (4) wires and insulate connections.

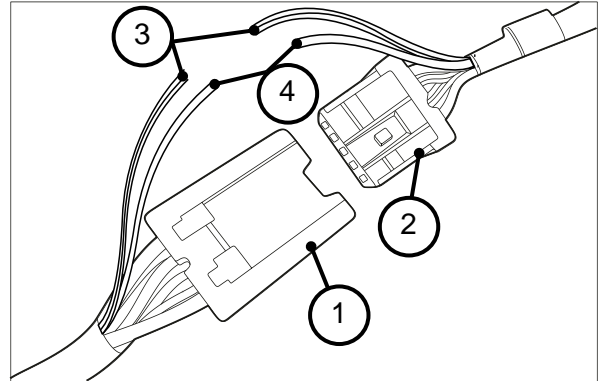

- 
70. Test the trailer wiring harness function using a light board or multi-meter. Secure all harnesses using cable ties (not supplied).
  71. Re-fit all removed parts and secure all fasteners, ensuring there are no squeaks or rattles.
  72. Place the fitting instructions in the glove box after fitment.

- 
73. Reattach bumper and lights by following steps 1-11 in reverse.

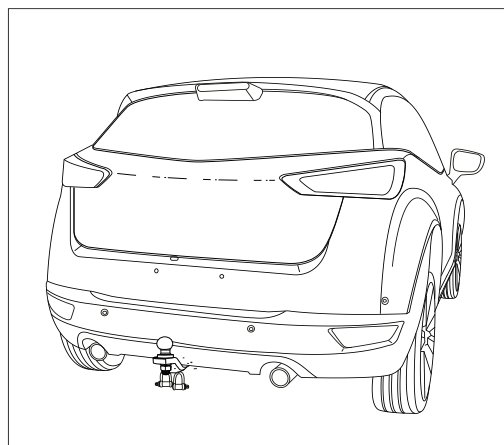



## CUSTOMER INFORMATION

PLACE THESE INSTRUCTIONS IN THE VEHICLE'S GLOVEBOX AFTER INSTALLATION

**THANK YOU FOR PURCHASING TRAILBOSS. WITH CORRECT MAINTENANCE AND CARE THIS PRODUCT WILL PROVIDE A LIFETIME OF TROUBLE-FREE OPERATION.**

### TOWBAR MAINTENANCE AND CARE:

1. Trailboss recommend that the towbar LUG or TBM (Trailer Ball Mount) Pull Pin and R-clip are removed and stored when not in use. Removal of LUG or TBM (Trailer Ball Mount) is advisable when not in use to assist with any of the following.
  - Ensure rear number plate is not obscured.
  - Allow maximum available departure angle and prevent any potential interference.
  - Prevent possible interference with vehicles reverse sensors or camera detecting a tow ball mount as an obstruction during reversing.
  - Removes towball mount as an obstruction for when moving around the rear of the vehicle.
2. Trailboss recommends routine inspection of your towbar to ensure trouble free towing.
  - Bolt security and tension should be regularly inspected and checked for correct tension. Replace any worn or defective parts with suitable grade & class fasteners. Inspection should be requested to coincide with vehicle major services.
3. It is the owner's responsibility to ensure towing and down ball weight capacities of the towing vehicle are not exceeded.
  - Towing and down ball weights allowable may differ according to model variations. Please refer to owner's manual or vehicle dealer to confirm exact rating for your vehicle model variant.
  - It is not uncommon for the vehicle tow rating to differ from the towbar rating. When this occurs, the lesser rating must be adhered to.
  - For vehicles fitted with enhanced vehicle functions that may be altered/changed when towing i.e Trailer sway mitigation, blind spot detection, adaptive cruise control etc. Please consult owner's manual to understand changes enabled when towing and after towing.

### WARRANTY INFORMATION:

Trailboss Towbars are covered by a Lifetime Warranty.

Our goods come with guarantees that cannot be excluded under the Australian Consumer Law. You are entitled to a replacement or refund for a major failure and for compensation for any other reasonably foreseeable loss or damage. You are also entitled to have the goods repaired or replaced if the goods fail to be of acceptable quality and the failure does not amount to a major failure.

For further details please contact customer service on 1800 812 017.

## PRO SERIES SILENT ANTI-RATTLE HITCH PIN

Your Trailboss towbar is equipped with a Pro Series Silent Anti-Rattle Hitch Pin technology to help reduce towbar tongue rattle in most driving conditions. Please ensure below instructions are understood and routine maintenance is carried out to ensure best towing experience.

Regularly inspect for wear and check the tightness of the Silent Anti-Rattle Hitch Pin. Follow instructions below to re-tighten the nut as necessary when movement and noise in the tow ball mount is noted.

- Before towing, ensure R-Clip is properly installed and hitch pin nut is installed and tensioned. Replacement parts are available from your Pro Series Distributor.

## TOWBALL MOUNT REMOVAL/INSTALLATION

### STEP 1

Insert Trailer Ball Mount (TBM) (a) into towbar hitchbox (b), aligning hole in TBM shank (c) with hole in hitchbox (d) (Fig. 1)

### STEP 2

Insert Silent Anti-Rattle Hitch Pin (e) through hole in hitchbox and hole in TBM shank (g); ensure the locators are inserted into the notches in the hitchbox (Fig. 2)

### STEP 3

Screw Silent Anti-Rattle Hitch Pin Nut (f) onto Smart Pin (g); tighten Smart Pin Nut until finger tight, ensuring TBM is restrained from up and down movement.

### STEP 4

Tighten Silent Anti-Rattle Hitch Pin Nut by turning nut a further 1/8th of a turn in the clockwise direction using a 24mm spanner (Fig. 4).

### STEP 5

Install Silent Anti-Rattle Hitch Pin R-Clip through the hole that provides best clearance or easiest access. (Fig. 5)

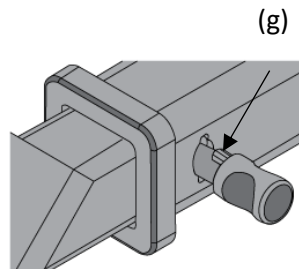
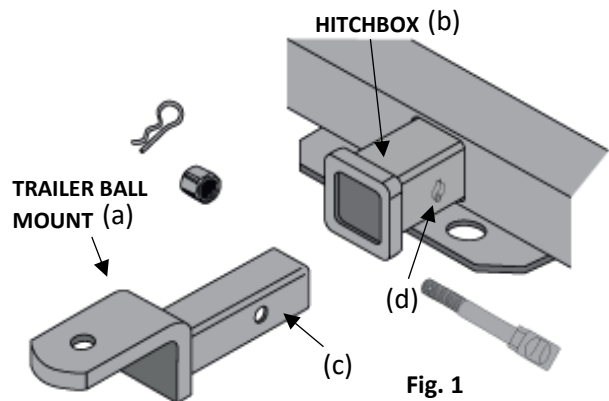

Fig. 2

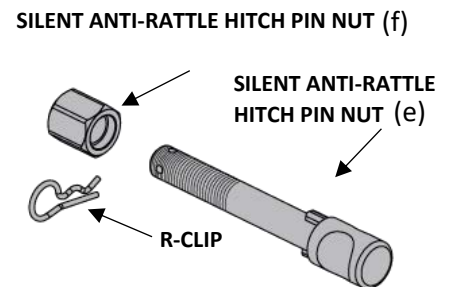

Fig. 3

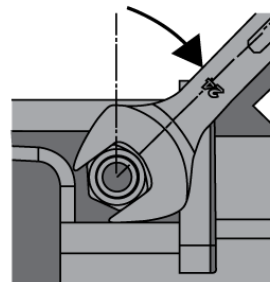

Fig. 4

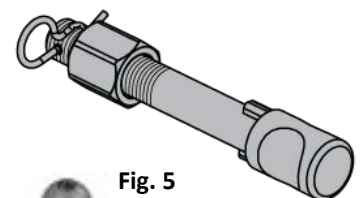

Fig. 5

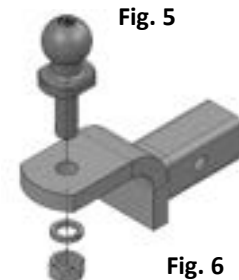

Fig. 6