

PRODUCT DETAILS:

Part Number:	MA90L	Maximum Towing Braked:	1200	kg
ECU Number:	04826	Maximum Towing Unbraked:	600	kg
Tail Harness Length Required:	1200 mm.	Maximum Static Ball Load:	80	kg
TBM/Lug Part Number:	07758			

FITTING DETAILS:

Towbar Installation Time:	60 Mins	RPA Disable/Other:	YES
Total Installation Time:	120 Mins		
Bumper Cut Required:	Yes		

Notes:

- Use tail 04943 to automatically disable RPA and Smart City Stop function where equipped

TRAILBOSS RECOMMENDS THAT INSTRUCTIONS ARE READ AND UNDERSTOOD COMPLETELY PRIOR TO FITMENT.

BEFORE YOU START:

Check all hardware items have been included refer to assembly diagram.
Please ensure this towbar is only fitted to vehicle models as per Trailboss application guide.

Bumper Cuts

Vehicle and bumper variations can and do occur during vehicle manufacture after initial towbar design. Fitment of towbar to vehicle and accuracy of bumper cut must be assessed prior to any bumper modifications made. Incorrect bumper cuts are not covered under Trailboss warranty.

NOTE: Bumper cuts need to be approached with care, refer to notes below.

- Bumper centreline – where the centreline of the bumper needs to be determined, the installer must assess centre point by measurement of bumper width or determining two symmetrical reference points to give centreline.
- Bumper edge – To assist with accurate bumper cut measurement, reference to the start of the bumper edge is now being commonly used.
 - Measure from bottom edge along bumper and around corner to the 70 mm point (Figure 1).
 - Do not measure from visible bumper front of corner, upwards (Figure 2).

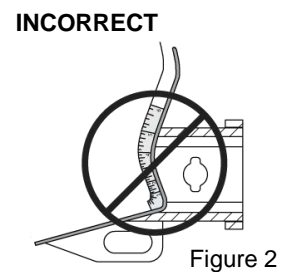
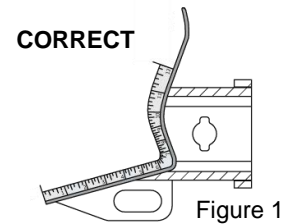

Drilling

- For any required drilling during installation, ensure that the area is clear of fuel, electrical & other components that may be damaged.
- All holes drilled into metal body panels shall have all burrs & swarf removed then coated with a suitable rust preventative paint.

Bolts/Fasteners

- Ensure that all hardware is fastened to correct torque as specified in this fitting instruction.
- All fasteners supplied with this product are used to achieve a specified clamp loading. If replacement is required ensure that fasteners of the same grade and class are used.

NOTE: Achieving correct torque is critical to proper installation and responsibility of the installer. Towbar failures attributed to tension issues from over tightening or under tightening are not covered by Trailboss warranty.

Product Labels

- a. Towbar load rating sticker provided with this product shall be conspicuously located on inside rear end of the driver's door.

WARNING:

Do not, drill, cut, weld or otherwise modify the towbar.

FOR TOWING PURPOSES ONLY - This towbar is designed and tested by Trailboss to adhere to ADR 62/02 which provides only for the expected load demands of towing.

i TOWBAR ASSEMBLY DIAGRAM

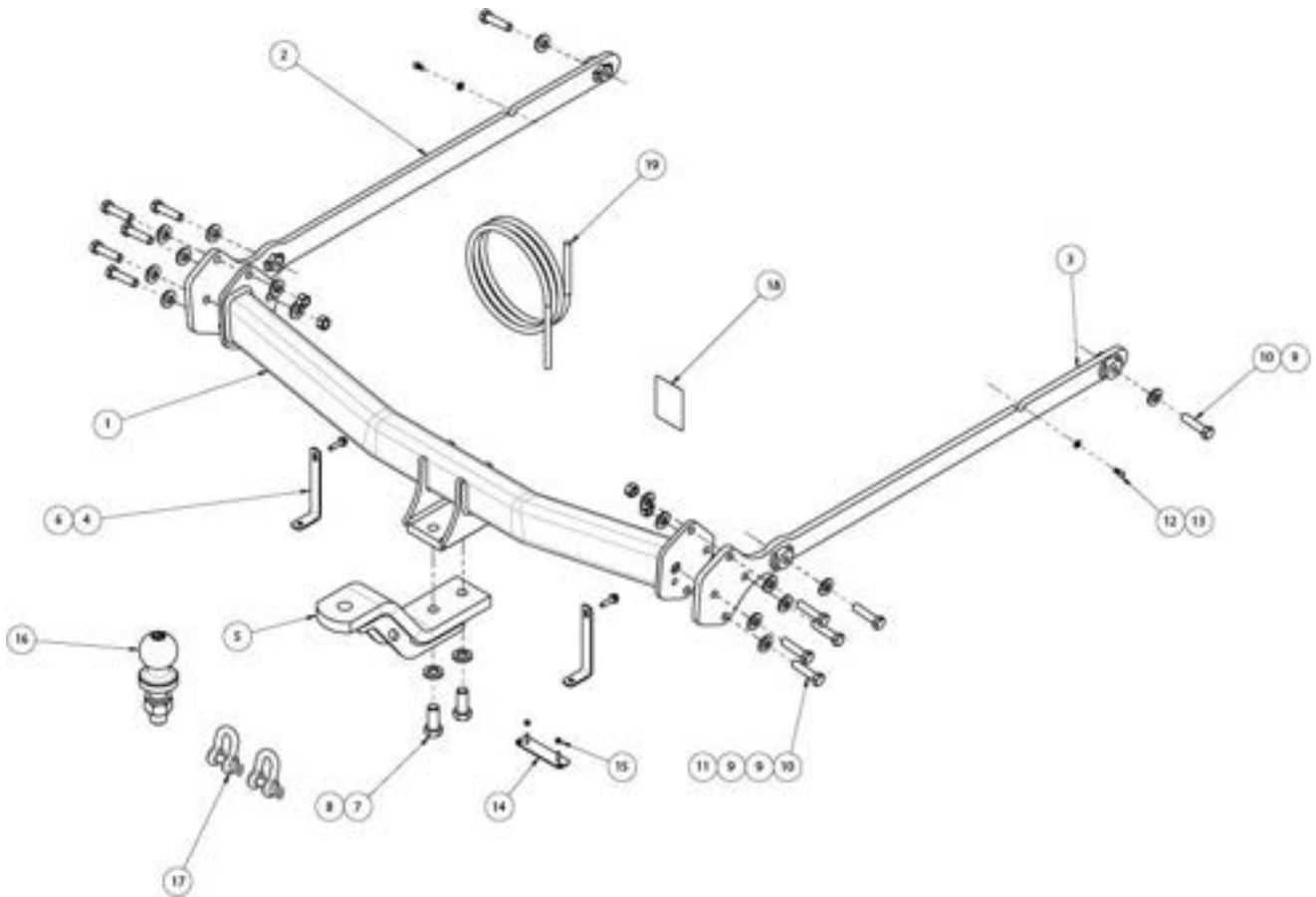

ITEM	DESCRIPTION	QTY
1	MAZDA 3 BP WELDED ASSEMBLY	1
2	LH SIDEARM ASSEMBLY	1
3	RH SIDEARM ASSEMBLY	1
4	BUMPER TAB	2
5	LUG ASSY	1
6	TEK SCREW 14-20 HEX HD 22mm	2
7	SET SCREW HEX HD M16x40x2.0P	2
8	WASHER SPRING M16x5x3.5	2
9	WASHER PLAIN M14x28x3	18
10	BOLT HEX HD M12x50x1.75P	12

ITEM	DESCRIPTION	QTY
11	NUT HEX M12x1.75P	6
12	CAP SCREW HEX HD M6x12x1.0P	2
13	WASHER PLAIN M6x12.5x1.2	2
14	PLUG BRACKET	1
15	NUT NYLON LOCK HEX M4x0.7P	2
16	TOWBALL 50mm	1
17	"D" SHACKLE 10mm	2
18	ACRYLIC COMPLIANCE LABEL	1
19	WIRING LOOM	1

1. Remove 3 x screws and 2 x scrivenets securing the underside bumper cover to the bumper support.

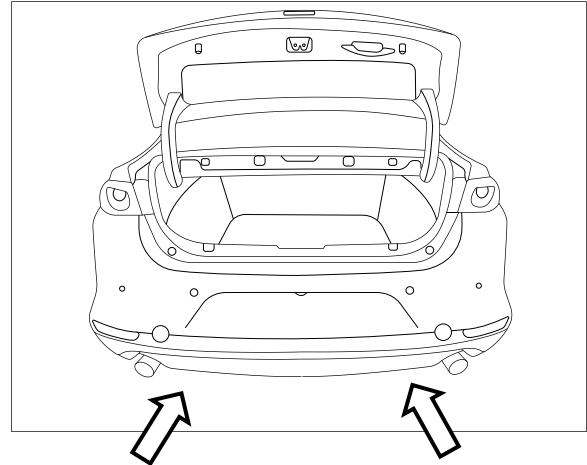

2. Remove 3 x screws from the left-hand underside of the bumper.

Repeat for opposite side.

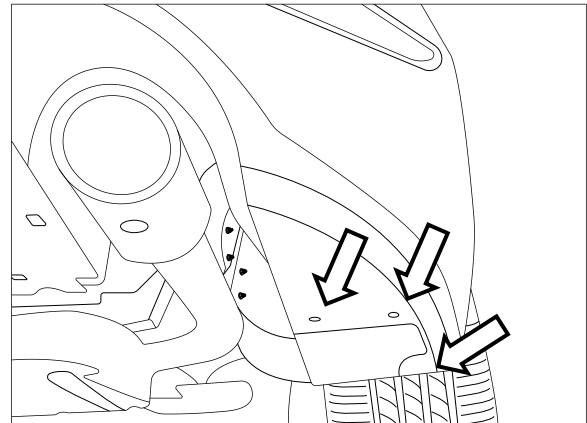

3. In the wheel arch remove 1 x scrivenets and 1 x screw.

Repeat for opposite side.

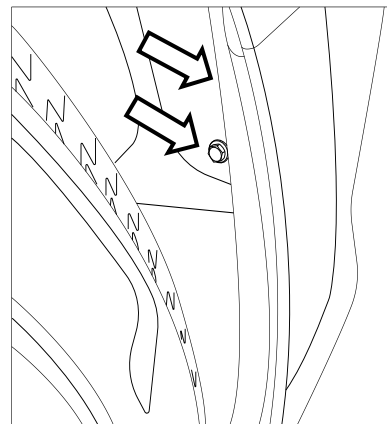

-
4. Partially peel back wheel arch liner to expose 2 x screws.

Remove 2 x screws.

Repeat for opposite side.

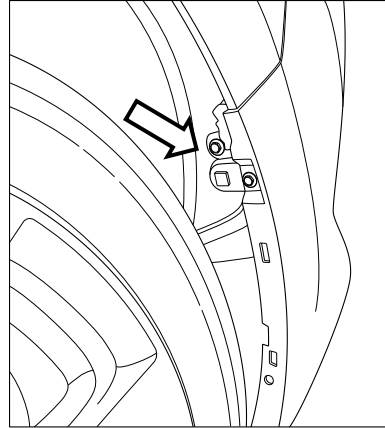

-
5. Open tail gate and remove 1 x screw cap cover and water channel cover. Remove the 3 x exposed screws.

Repeat for opposite side.

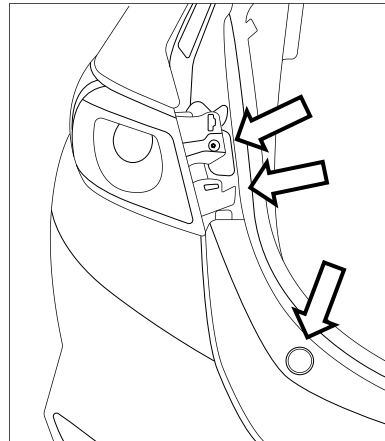

-
6. In the luggage compartment remove the boot liner carpet (1).
On right-hand side disconnect wiring and 1 x nut securing tail light.
Pull tail light rearwards to dislodge.

Repeat for opposite side.

7. Fold down the rear seats (2) by pulling the release levers (3).

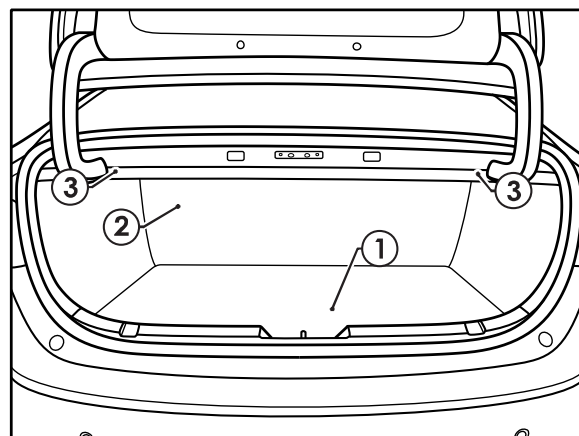

8. Remove the foam tool storage trays (1).

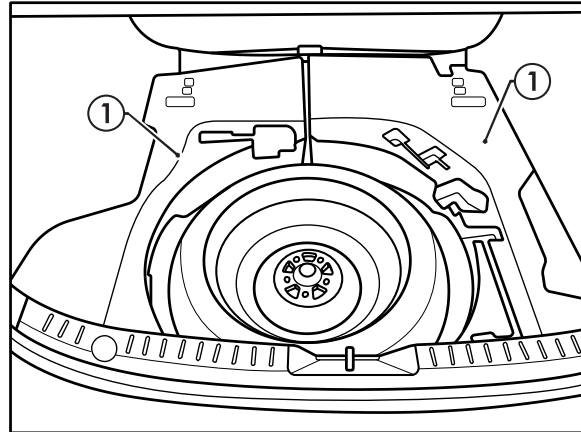

9. On the luggage compartment scuff trim (1), remove the two trim clips (2).
10. Remove the rear scuff trim by pulling in an upwards direction.

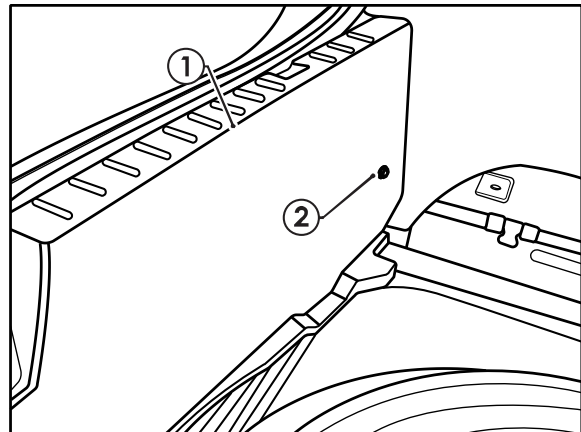

11. On the LHS, remove the 3 trim clips (1) securing the LHS trim (2).
12. Carefully fold the LHS trim out and under the boot arm.

Repeat for RHS.

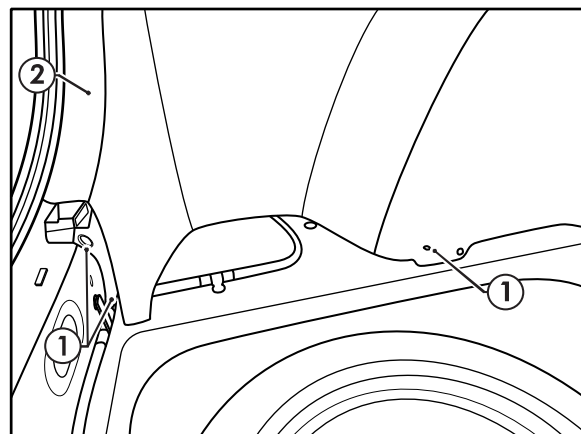

13. Behind the previously removed LHS trim, remove the 2 trim clips (1) securing the plastic trim (2).
14. Remove the LHS plastic trim (2).

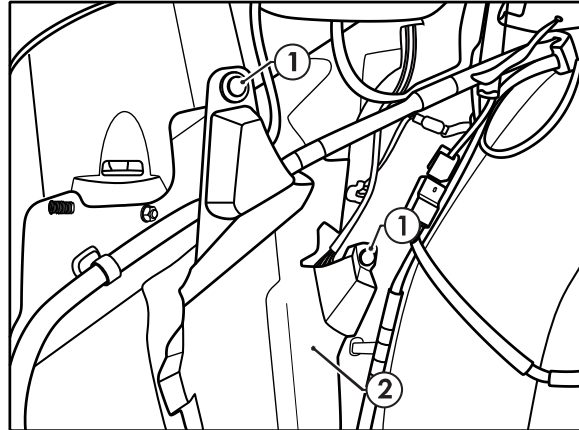

15. In right-hand side interior, disconnect 3 x plugs connected to bumper and feed through grommet hole.

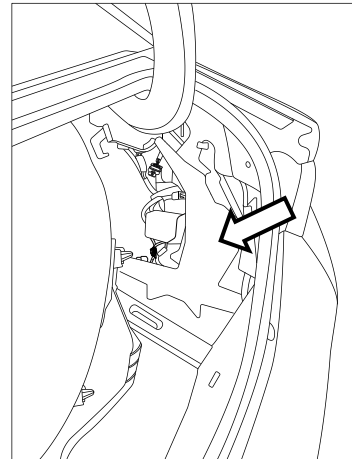

16. Remove 1 x screw and 1 x scrivets securing bumper in the tail light cavity.

Repeat for opposite side.

Peel away bumper and put aside.

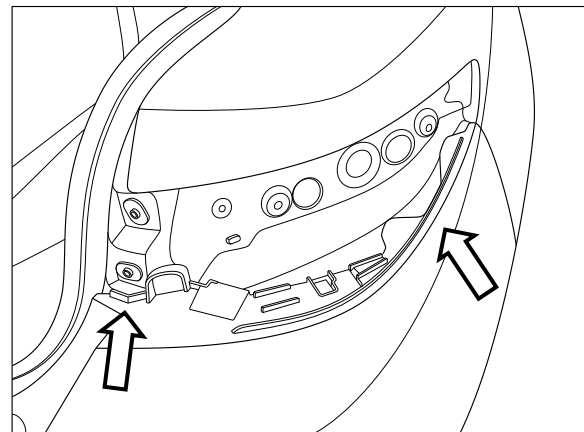

-
17. Remove and discard impact beam secured by 4 x M12 nuts per side.

Remove and discard bumper support secured by 2 x screws.

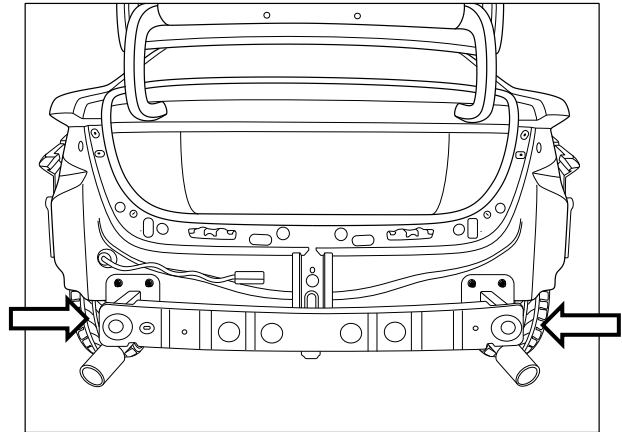

-
18. Underneath the vehicle, locate the parking brake brackets on both chassis rails.

Remove the existing M6 bolts and replace with the M6 bolts provided complete with 1 x washer per bolt.

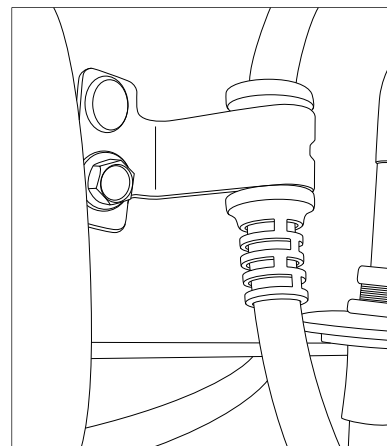

-
19. Insert left-hand sidearm into chassis rail.

Remove tape concealing 2 x mounting points on chassis and loosely secure sidearm with 2 x M12 bolts, complete with 1 x washer per bolt.

NOTE: ensure welded nuts are facing inwards and notch is on top.

Repeat for opposite side.



-
20. With 2 people, lift the centre section assembly up to the sidearms. Loosely secure with 3 x M12 bolts per side, complete with 2 x washers and 1 x nut per bolt

Secure sidearms to centre section with the remaining 2 x M12 bolts (1 per side), complete with 1 x washer per bolt, inserted into captive nuts.

Torque all M12 fasteners to 77 Nm

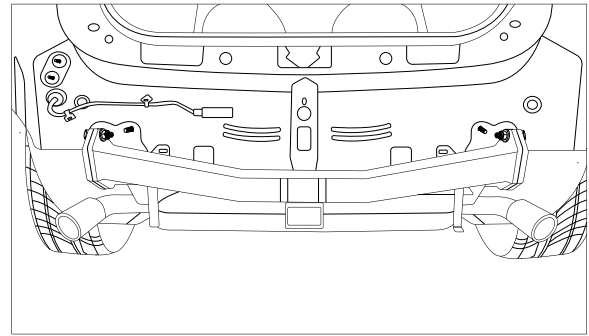

-
21. Secure bumper brackets to rear of crosstube with 1 x tek screw per bracket. Use the hole closest to the centre of the crosstube on either side as shown.

Ensure bracket fold is facing rearwards.

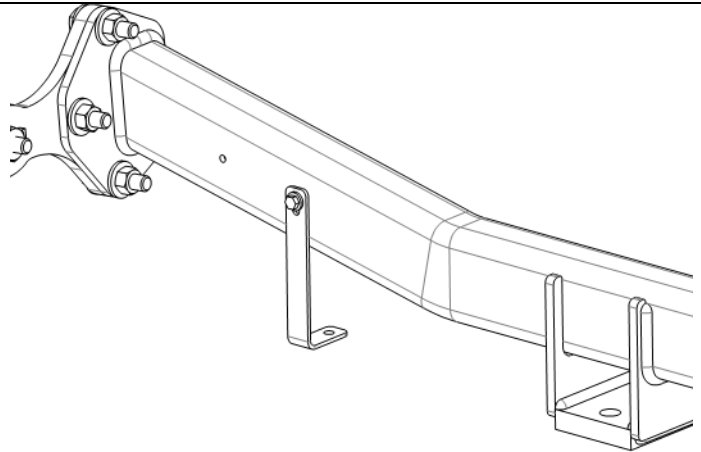

-
22. For the plug bracket find an appropriate position on the bumper then mark out and drill 2 x \varnothing 5mm holes 69mm apart on bumper skin to support plug bracket.

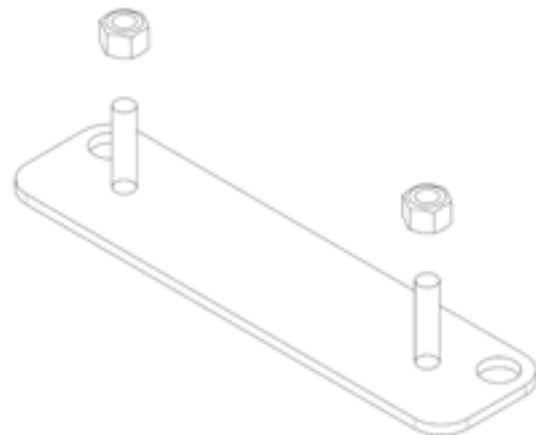

23. On the bottom edge of the bumper locate the centre vertical. Cut approximately 100mm wide and 75mm up from the edge as measure from outside the face of bumper.

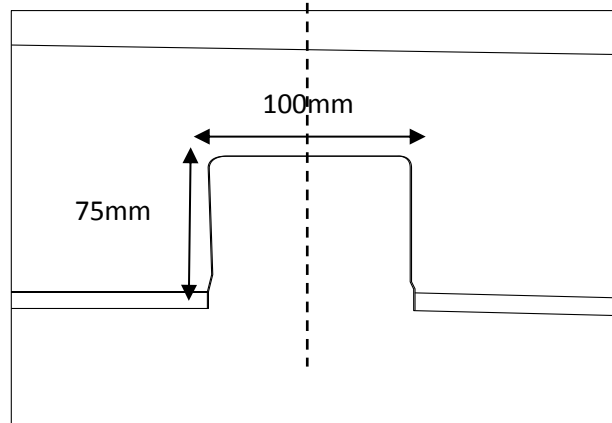

IMPORTANT

Due to possible vehicle variations, always confirm any noted vehicle colour wires with a multi-meter to ensure the correct function is identified before soldering or scotch locking. For vehicle wires denoted with two colours (example; RED/GREEN) the first colour will always be the main wire colour while the second colour is the thinner trace colour on the wire.

24. In the engine bay, disconnect the vehicle battery negative terminal (1).

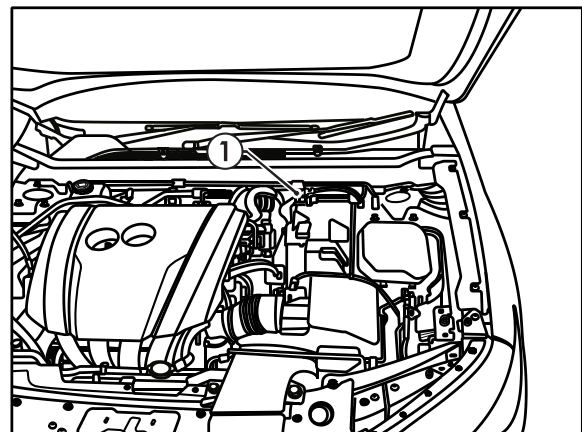

25. Near the RHS tail light, patch in the RHS branch patch connectors (1) in between the vehicle wiring (2) and the tail light wiring (3).

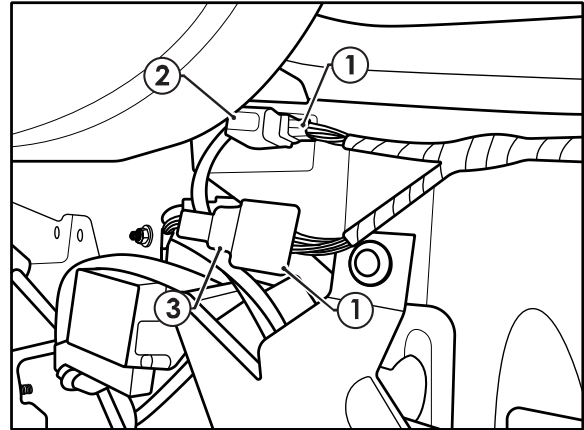

26. Route the LHS patch across to the LHS tail light connectors.
27. Patch in the LHS branch patch connectors (1) in between the vehicle wiring (2) and the tail light wiring (3).
28. Secure to the existing vehicle wiring using the supplied Cable Ties.

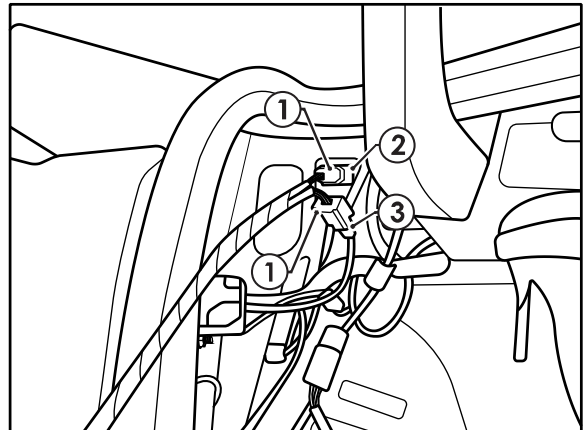

29. On the LHS, locate the vehicle reverse parking module (1).
30. Disconnect the 16-way connector (2) from the module and patch in the mating RPA disable/trailer activation connection in between the vehicle wiring and the RPA module.

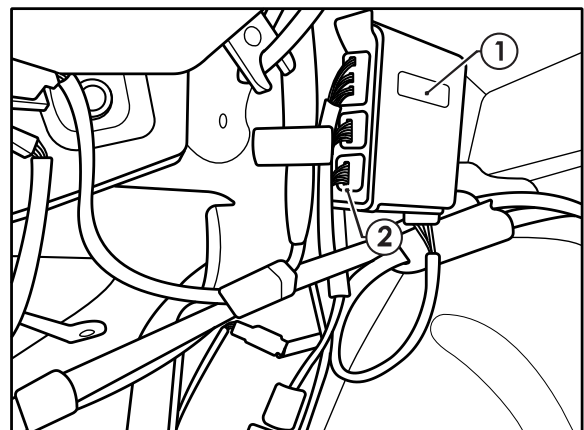

31. Using an alcohol wipe, clean the LHS inner sheet metal area (1) and the underside of the ECU (04826) (2).
32. Connect the trailer patch 12-way connector (3) to the ECU.
33. Apply double sided tape to the ECU (2) and secure it to the vehicle sheet metal.
34. Connect the ground wire to the vehicle earthing point (4).
35. Route the orange wire (5) towards the front of the vehicle.

Note: Mount the ECU, ensuring the connector is

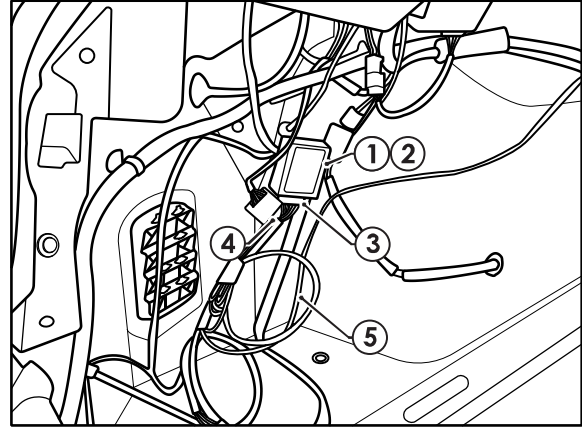

36. With the weather seal (1) removed, feed the power wire through to the cabin from the boot.

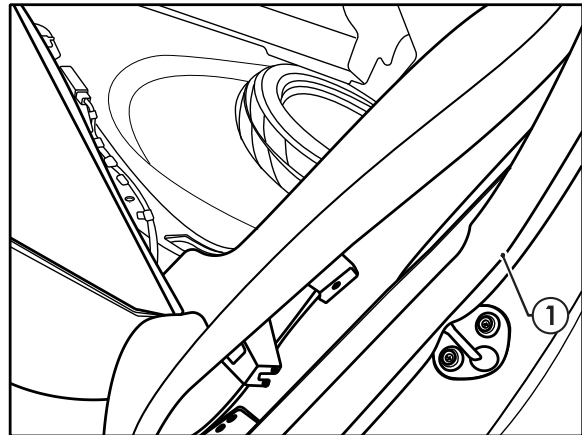

37. With the front and rear scuff trims removed, continue routing the power wire (1) towards the front of the vehicle, tucking the power wire under the B pillar trim (2).

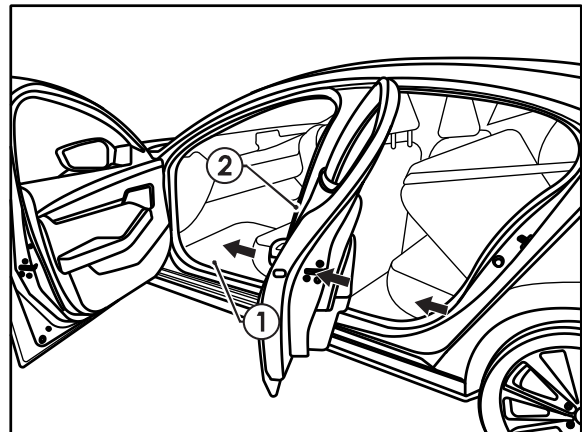

38. Remove the cover on the LHS kick panel (1).
39. Route the orange wire towards the fuse box (2).

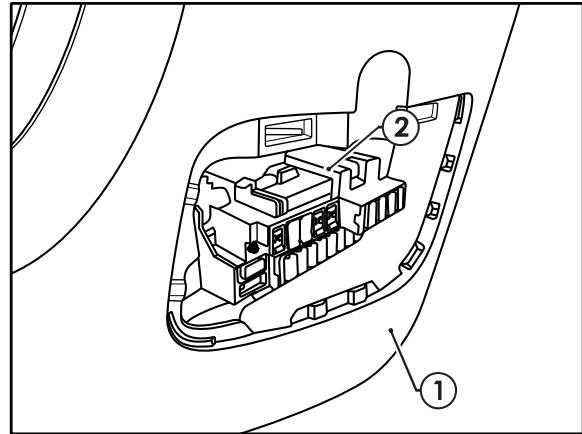

40. On the vehicle fuse box (1), remove the vehicle fuse 15 Amp Fuse (F16) (2) and discard.
41. On the Add-A-Fuse (3), insert the supplied 20 amp fuse (4) into the Add-A-Fuse top slot and then insert the supplied 15 amp fuse (5) into the bottom slot.
42. In the orientation shown, insert the Add-A-Fuse (3) into the slot occupied by the vehicle fuse (2).
43. Connect the Add-A-Fuse (3) to the main harness.

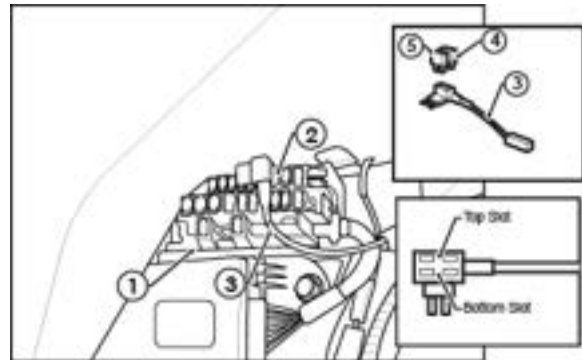

Note: To maintain correct electrical operation, ensure you insert the fuse adaptor into the allocated slot and in the orientation shown.

44. Drill a 30mm grommet hole (1) in a suitable location to enable the tail harness to be routed from the towbar to the ECU.

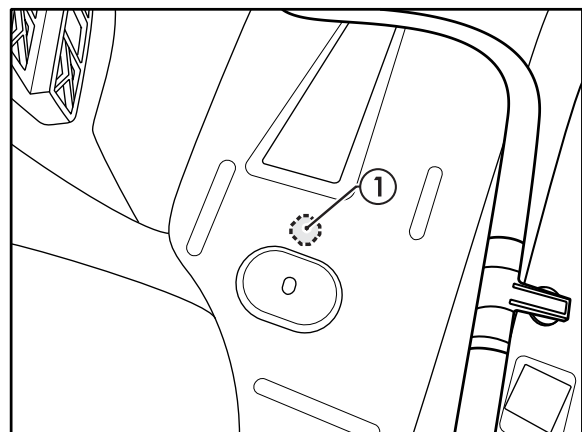

45. With the rear bumper removed, secure tail harness to towbar.
46. Route tail harness up through chassis and previously drilled 30mm hole.
47. Seat grommet in 30mm hole and route to trailer harness blue connector on patch loom.

Note: Keep harness routing clear of all sharp edges, moving parts and places of extreme heat.

Note: Ensure grommet is seated correctly and makes a good seal.

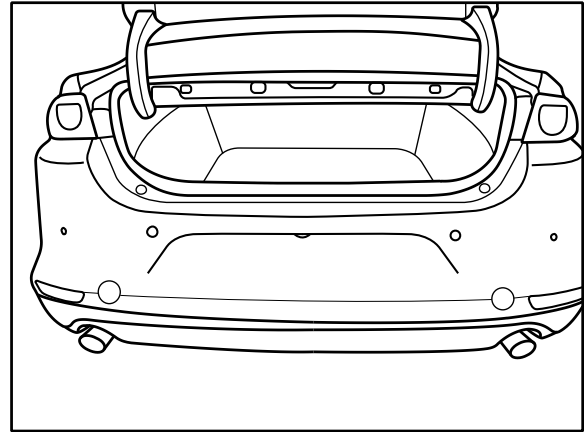

48. Connect the tail harness (tail length 1200mm) 8- way connector (1) to the trailer patch mating 8- way connector (2).
49. Cut-off, crimp the tail harness GREY and GREY/BLACK wires (3) to the trailer patch matching GREY and GREY/BLACK wires (4).
50. Apply silicone grease (not supplied) (5) to waterproof connector.

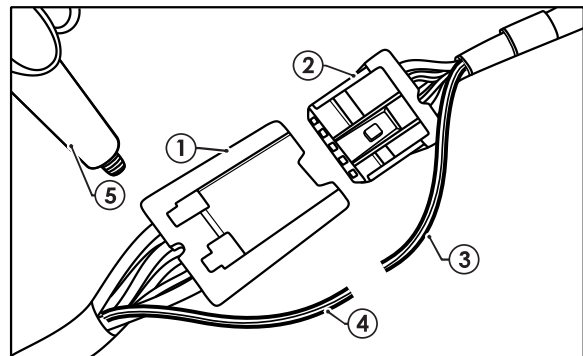

51. Secure all harness using supplied Cable Ties.
52. Test the trailer patch function using a light board or multi-meter.
53. Re-fit all removed parts and secure all fasteners, ensuring there are no squeaks or rattles.
54. Place the fitting instructions in the glove box after fitment.



CUSTOMER INFORMATION

PLACE THESE INSTRUCTIONS IN THE
VEHICLE'S GLOVEBOX AFTER INSTALLATION

**THANK YOU FOR PURCHASING TRAILBOSS. WITH CORRECT MAINTENANCE AND CARE
THIS PRODUCT WILL PROVIDE A LIFETIME OF TROUBLE-FREE OPERATION.**

TOWBAR MAINTENANCE AND CARE:

1. Trailboss recommend that the towbar LUG or TBM (Trailer Ball Mount) Pull Pin and R-clip are removed and stored when not in use. Removal of LUG or TBM (Trailer Ball Mount) is advisable when not in use to assist with any of the following.
 - Ensure rear number plate is not obscured.
 - Allow maximum available departure angle and prevent any potential interference.
 - Prevent possible interference with vehicles reverse sensors or camera detecting a tow ball mount as an obstruction during reversing.
 - Removes towball mount as an obstruction for when moving around the rear of the vehicle.
2. Trailboss recommends routine inspection of your towbar to ensure trouble free towing.
 - Bolt security and tension should be regularly inspected and checked for correct tension. Replace any worn or defective parts with suitable grade & class fasteners. Inspection should be requested to coincide with vehicle major services.
3. It is the owner's responsibility to ensure towing and down ball weight capacities of the towing vehicle are not exceeded.
 - Towing and down ball weights allowable may differ according to model variations. Please refer to owner's manual or vehicle dealer to confirm exact rating for your vehicle model variant.
 - It is not uncommon for the vehicle tow rating to differ from the towbar rating. When this occurs, the lesser rating must be adhered to.
 - For vehicles fitted with enhanced vehicle functions that may be altered/changed when towing i.e Trailer sway mitigation, blind spot detection, adaptive cruise control etc. Please consult owner's manual to understand changes enabled when towing and after towing.

WARRANTY INFORMATION:

Trailboss Towbars are covered by a Lifetime Warranty.

Our goods come with guarantees that cannot be excluded under the Australian Consumer Law. You are entitled to a replacement or refund for a major failure and for compensation for any other reasonably foreseeable loss or damage. You are also entitled to have the goods repaired or replaced if the goods fail to be of acceptable quality and the failure does not amount to a major failure.

For further details please contact customer service on 1800 812 017.

PRO SERIES SILENT ANTI-RATTLE HITCH PIN

Your Trailboss towbar is equipped with a Pro Series Silent Anti-Rattle Hitch Pin technology to help reduce towbar tongue rattle in most driving conditions. Please ensure below instructions are understood and routine maintenance is carried out to ensure best towing experience.

Regularly inspect for wear and check the tightness of the Silent Anti-Rattle Hitch Pin. Follow instructions below to re-tighten the nut as necessary when movement and noise in the tow ball mount is noted.

- Before towing, ensure R-Clip is properly installed and hitch pin nut is installed and tensioned. Replacement parts are available from your Pro Series Distributor.

TOWBALL MOUNT REMOVAL/INSTALLATION

STEP 1

Insert Trailer Ball Mount (TBM) (a) into towbar hitchbox (b), aligning hole in TBM shank (c) with hole in hitchbox (d) (Fig. 1)

STEP 2

Insert Silent Anti-Rattle Hitch Pin (e) through hole in hitchbox and hole in TBM shank (g); ensure the locators are inserted into the notches in the hitchbox (Fig. 2)

STEP 3

Screw Silent Anti-Rattle Hitch Pin (f) onto Smart Pin (g); tighten Smart Pin Nut until finger tight, ensuring TBM is restrained from up and down movement.

STEP 4

Tighten Silent Anti-Rattle Hitch Pin Nut by turning nut a further 1/8th of a turn in the clockwise direction using a 24mm spanner (Fig. 4).

STEP 5

Install Silent Anti-Rattle Hitch Pin R-Clip through the hole that provides best clearance or easiest access. (Fig. 5)

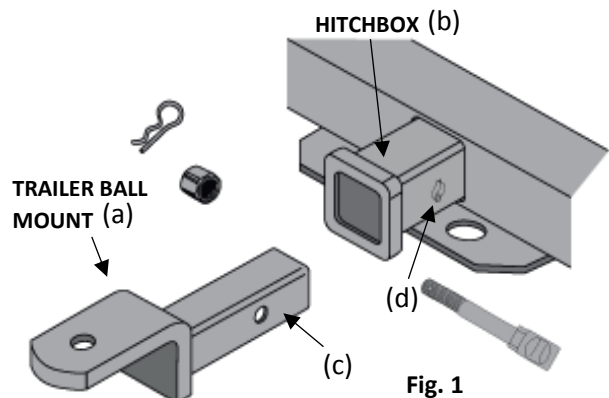

Fig. 1

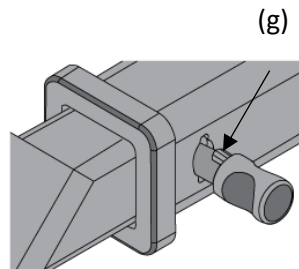

Fig. 2

SILENT ANTI-RATTLE HITCH PIN NUT (f)

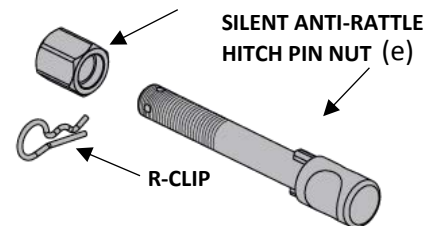

Fig. 3

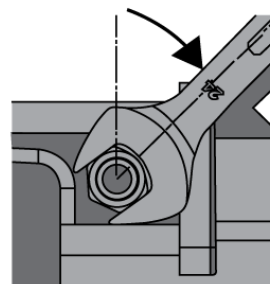

Fig. 4

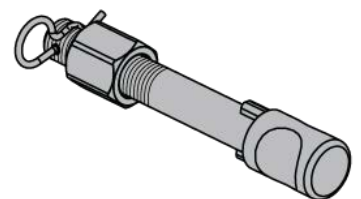

Fig. 5