

TRAILBOSS

Towbar Fitting Instructions To Suit **HOLDEN MALIBU 2013 ON** Part Number **HD94L** Rating **1200/120 kg**

PLACE THESE INSTRUCTIONS IN THE VEHICLE'S GLOVEBOX AFTER INSTALLATION IS COMPLETED

WARNING:

1. Do not, drill, cut, weld or otherwise modify the tow bar.
2. If you are using electric welding on a motor vehicle, **always** check that the vehicle is not equipped with electronic engine or instrument management equipment. Failure to do so could **destroy** any onboard computers. If in doubt, check with the vehicle's manufacturer.
3. The high tensile fasteners supplied with this product were used to achieve the specified rating. If replacement is required ensure that fasteners of the same rating & quality are used. Contact an authorised **Trailboss** dealer if further information is required.

General:

1. Ensure all hardware items have been included refer to assembly diagram.
2. It is recommended that the instructions are read through and completely understood before making any attempt to fit this product.
3. Be wary of any changes to vehicle designs or other accessories that may conflict with the installation of this product.
4. Before drilling ensure that the area is clear of fuel, electrical & other components.
5. All holes drilled into the body panels shall have all burrs & swarf removed then coated with a suitable rust preventative paint.
6. For vehicles that require the bumper to be cut. Ensure cut out area is in correct position on the vehicle prior to cutting the bumper.
7. The high tensile fasteners supplied with this product were used to achieve the specified rating. If replacement is required ensure that fasteners of the same rating & quality are used. Contact an authorized **Trailboss** dealer if further information is required.
8. Ensure that all hardware is fastened to torque list below check fasteners on regular basis.
9. Tow bar load rating sticker provided with this product shall be conspicuously located on inside rear end of the driver's door. **(See diagram below)**.
10. Trailboss recommends that you check your tow ball to ensure that it complies with the Australian standards **AS 4177.2**.
11. **PLEASE NOTE:** It is advised to remove your lug or tbm when not actually towing so as to produce a clear view of the vehicles registration plate if obscured, and to also provide maximum available departure angle
12. Pull Pin must be fit in down position.

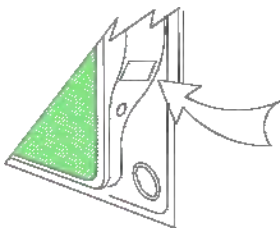

Place load rating sticker
inside driver's door here

FOR TRAILER TOWING PURPOSES ONLY
For towing capacity details please refer to vehicle owner's manual or to the manufacturer. Overloading can void your warranties.

RECOMMENDED ASSEMBLY TORQUE LISTING

<u>Diameter</u>	<u>Grade 8.8 Bolt</u>
M6	9.5 Nm
M8	21.7 Nm
M10	43.4 Nm
M12	77.3Nm
M14	146 Nm
M16	189.8 Nm

Tow bar Maintenance and Care.

Trailboss recommends that bolt torque's, as listed below, are routinely and regularly inspected and checked for correct tension. Replace any worn or defective parts.

We recommended to remove Tow Ball Mounts (TBM's, tongues or lugs) when not being used for any considerable length of time.

So as to avoid injury, when not towing it is suggested that the tongue, Pull Pin and R-clip are removed then stored in a safe, clean and dry place, away from excessive moisture.



Towbar Fitting Instructions
 To Suit **HOLDEN MALIBU 2013 ON**
 Part Number **HD94L**
 Rating **1200/120 kg**

PLACE THESE INSTRUCTIONS IN THE VEHICLE'S GLOVEBOX AFTER INSTALLATION IS COMPLETED

Hitch Pull Pins and spring "R" clips are regularly checked for proper installation. Replace any worn or defective parts.

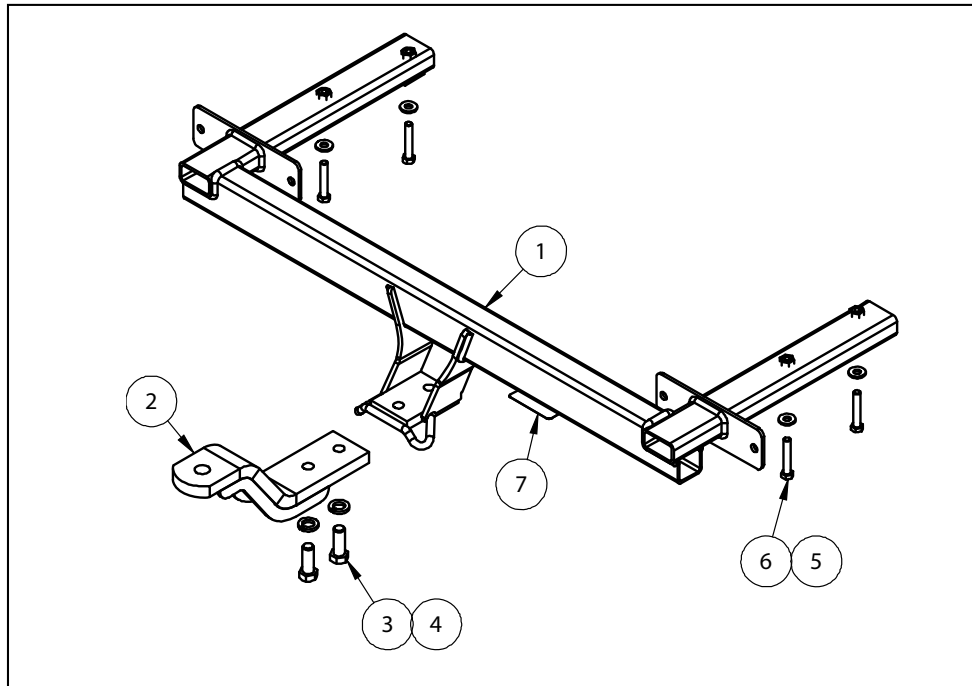

QTY	DESCRIPTION	ITEM NO
1	WELDED ASSEMBLY	1
1	LUG ASSEMBLY	2
2	M16x45x2.0P BOLT	3
2	M16 SPRING WASHER	4
4	M10 FLAT WASHER	5
4	M10x60x1.5P BOLT	6
1	ACRYLIC CP LABEL	7

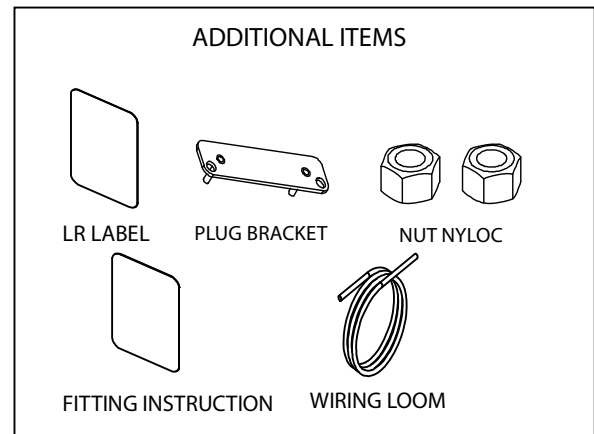

TRAILBOSS

Towbar Fitting Instructions
To Suit **HOLDEN MALIBU 2013 ON**
Part Number **HD94L**
Rating **1200/120 kg**

PLACE THESE INSTRUCTIONS IN THE VEHICLE'S GLOVEBOX AFTER INSTALLATION IS COMPLETED

INSTRUCTION:

1. Remove 3x Screws from inside of wheel arc for both LH & RH side.
2. Remove 4x Scrivets from underside of Bumper bar and 2x Screws.
3. Inside the Boot remove interior paneling so as to get to the rear lights.
4. Remove 3x Plastic Nuts from back of rear lights inside of the boot and unplug the lights.
5. Pull on Bumper Bar to release from clips, rear lights will also come with Bumper Bar.
6. Remove the Impact Beam and discard, but retain the Impact Beam mounting nuts so as to use in the mounting of the Towbar.
7. Remove 2x Bolts from the exhaust hangers for both the LH & RH side and remove handers.
8. Offer Towbar to vehicle and use 4x the mounting Nuts from the Impact Beam to secure the Towbar as well as the 4x Bolts supplied.

Torque all bolts to specifications provided on Page 1.

Refit Bumper Bar and all other components in reverse order.

9. Create Bumper Cut in middle of Bumper Bar measuring 110mm from the bottom lip of bumper and 110mm wide.

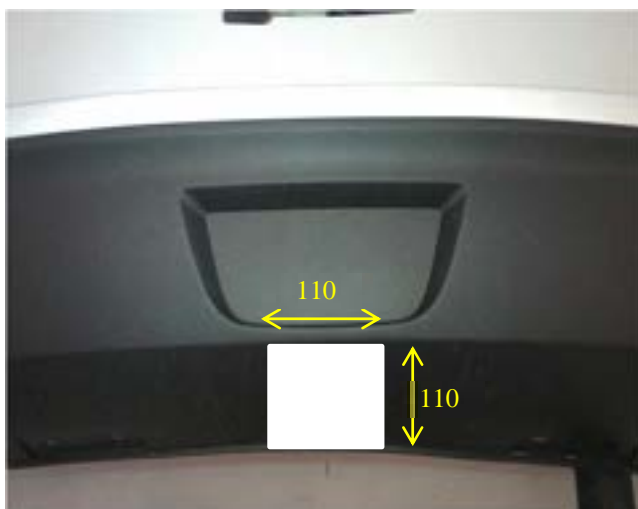



Wiring Loom Fitting Instructions
To Suit Holden Malibu
Part Number 100958-WL

Wiring Loom Installation Instructions

Holden Malibu
Part No: 100958-WL

Tail Harness Length Required: 1200mm
ECU Required: 04839

Wiring Loom Installation Time: Approx 15 Mins

TRAILBOSS

Wiring Loom Fitting Instructions To Suit Holden Malibu Part Number 100958-WL

1. In the rear of the luggage compartment, remove the floor carpet cover.
2. Remove the LHS foam support.
3. Remove the LHS luggage compartment trim by removing the two clips.
4. On the rear of the vehicle, drill a Ø30mm hole (1) next to the existing vehicle grommet.



5. Inside the LHS of the luggage compartment, apply double sided tape to the ECU and secure it to the vehicle sheet metal in a suitable location.
6. Connect the trailer patch 12-way connector to the ECU.

Note: Ensure ECU connector is facing downwards.

7. Disconnect the 30-way female connector (1) and following the table below, house the trailer patch terminals into their corresponding pins.

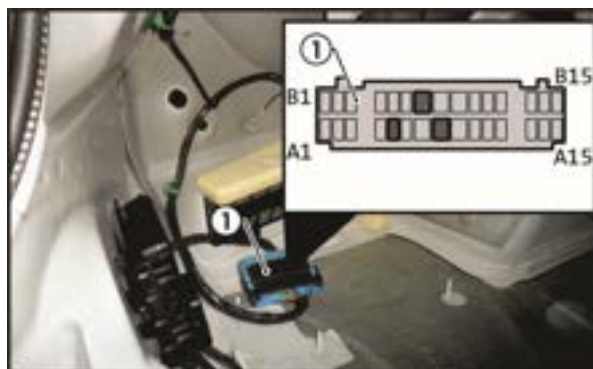

+12V	RED	PIN A8
GND	WHITE	PIN B7
CAN	GN/BK	PIN A5



Wiring Loom Fitting Instructions
To Suit Holden Malibu
Part Number 100958-WL

8. Connect the tail harness (tail length 1200mm) 8-way connector to the trailer patch mating 8-way connector.
9. Test the trailer patch function using a light board or multi meter.
10. Secure all harnesses using cable ties (not supplied).
11. Re-fit all removed parts and secure all fasteners, ensuring there are no squeaks or rattles.
12. Place the fitting instructions in the glove box after fitment.