



# TOWBAR INSTALLATION INSTRUCTIONS

PART NUMBER 03511RW

MAZDA CX-8 CL4



## PRODUCT DETAILS:

Part Number:	03511RW	Maximum Towing Braked:	2000	kg
ECU Number:	04826	Maximum Towing Unbraked:	750	kg
Tail Harness Length Required:	1800 mm	Maximum Static Ball Load:	150	kg
TBM/Lug Part Number:	21325			
Wiring Part Number:	101257-WL			

## FITTING DETAILS:

Towbar Installation Time:	60 Mins.	Hayman Reese SmartCODE Solution Required:	NO
Wiring Installation Time:	60 Mins.	RPA Disable/Other:	YES
Total Installation Time:	120 Mins.		
Bumper Cut Required:	Yes		

### Note:

- Tail 04944 can be used to disable RPA & Smart City Stop (where fitted) automatically via loom.



# TOWBAR INSTALLATION INSTRUCTIONS

PART NUMBER 03511RW

MAZDA CX-8 CL4

**ENSURE THAT INSTRUCTIONS ARE UNDERSTOOD PRIOR TO FITMENT.**

## **i** BEFORE YOU START:

Hayman Reese recommends that instructions are read completely prior to fitment. Check all hardware items have been included refer to assembly diagram. Please ensure this towbar is only fitted to vehicle models as per Hayman Reese application guide ([www.haymanreese.com.au](http://www.haymanreese.com.au)).

### Bumper Cuts



Vehicle and bumper variations can and do occur during vehicle manufacture after initial towbar design. Fitment of towbar to vehicle and accuracy of bumper cut must be assessed prior to any bumper modifications made. Incorrect bumper cuts are not covered under Hayman Reese warranty.

**NOTE: Bumper cuts need to be approached with care, refer to notes below.**

- Bumper centreline – where the centreline of the bumper needs to be determined, the installer must assess centre point by measurement of bumper width or determining two symmetrical reference points to give centreline.
- Bumper edge – To assist with accurate bumper cut measurement, reference to the start of the bumper edge is now being commonly used.
  - Measure from bottom edge along bumper and around corner to the 70 mm point (Figure 1).
  - Do not measure from visible bumper front of corner, upwards (Figure 2).

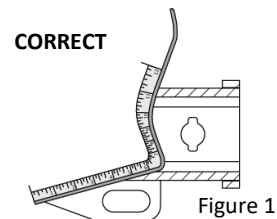

Figure 1

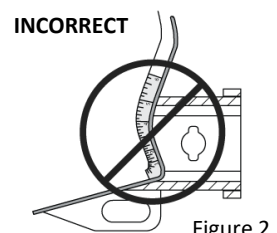

Figure 2

### Drilling

- For any required drilling during installation, ensure that the area is clear of fuel, electrical & other components that may be damaged.
- All holes drilled into the body panels shall have all burrs & swarf removed then coated with a suitable rust preventative paint.

### Bolts/Fasteners

- Ensure that all hardware is fastened to correct torque as specified in this fitting instruction.
- All fasteners supplied with this product are used to achieve a specified clamp loading. If replacement is required ensure that fasteners of the same grade and class are used.



**NOTE: Achieving correct torque is critical to proper installation and responsibility of the installer. Towbar failures attributed to tension issues from over tightening or under tightening are not covered by Hayman Reese warranty.**

### Product Labels

- a. Towbar load rating sticker provided with this product shall be conspicuously located on inside rear end of the driver's door.
- b. Powertrain Control Module (PCM)/Body Control Module (BCM) upgrade warning label will be provided in towbar kit for vehicles as required. Affix warning label in door and owner's handbook.

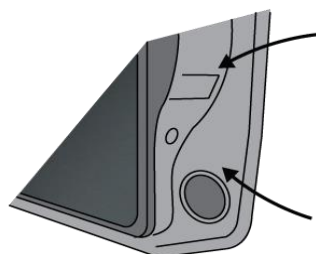

Place **Load Rating sticker** inside driver's door here

Place **Vehicle PCM/ BCM upgrade warning label** in door AND on front cover of owner's service handbook

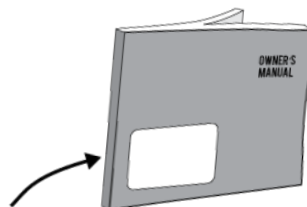

## **WARNING:**

**Do not, drill, cut, weld or otherwise modify the towbar.**

**FOR TOWING PURPOSES ONLY - This towbar is designed and tested by Hayman Reese to adhere to ADR 62/02 which provides only for the expected load demands of towing.**



# TOWBAR INSTALLATION INSTRUCTIONS

PART NUMBER 03511RW

MAZDA CX-8 CL4

## TOWBAR ASSEMBLY DIAGRAM

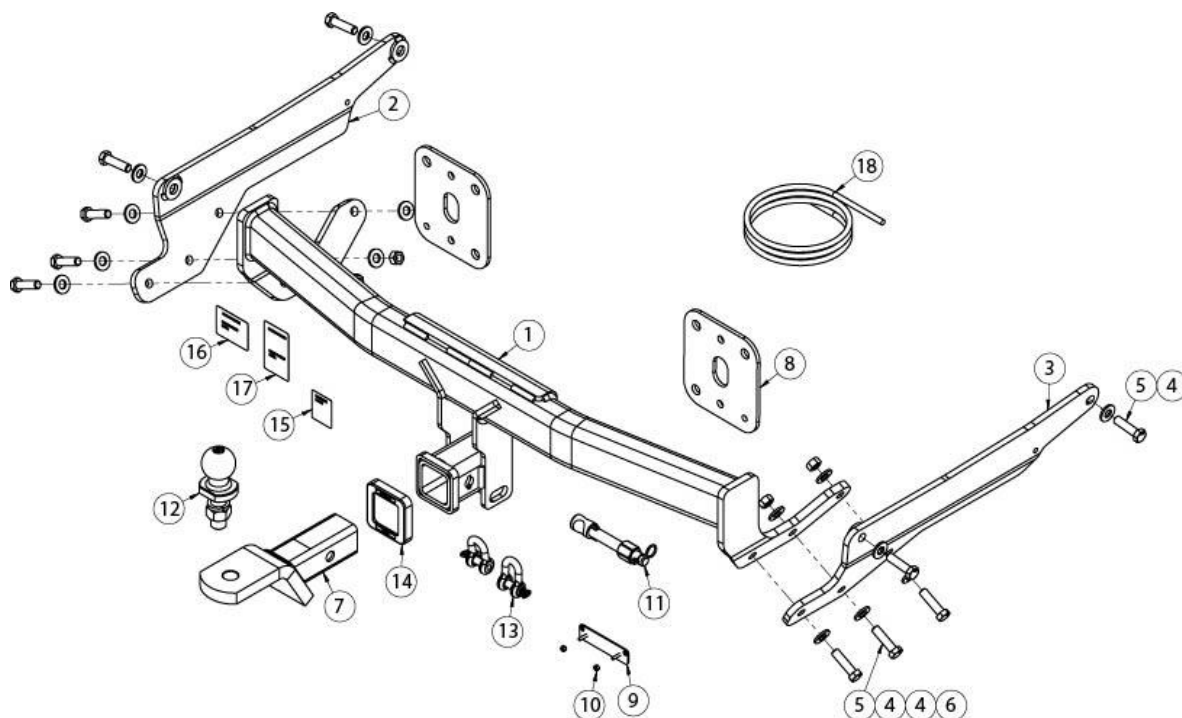

ITEM	DESCRIPTION	QTY
1	MAZDA CX8 CL4 WELDED ASSY	1
2	SIDE ARM ASSY LH	1
3	SIDE ARM ASSY RH	1
4	WASHER PLAIN M12x27x3.0mm	16
5	SET SCREW HEX HD M12x45x1.25P	10
6	NUT HEX HD M12x1.25P	6
7	TRAILER BALL MOUNT	1
8	BACK PANEL PLATE	2
9	PLUG BRACKET	1
10	NUT NYLOC HEX HD M4x0.7P	2
11	SMART PIN GOLD	1
12	TOWBALL 50mm	1
13	"D" SHACKLE 10mm	2
14	HITCH BOX COLLAR COVER	1
15	HAYMAN REESE LOGO STICKER	1
16	COMPLIANCE LABEL	1
17	LOAD RATING LABEL	1
18	WIRING LOOM	1



# TOWBAR INSTALLATION INSTRUCTIONS

PART NUMBER 03511RW

MAZDA CX-8 CL4

1. Open tailgate, lift exposed cover and remove 1 x Philips screw.
2. Remove tailgate stopper secured with 1 x Torx screw.
3. Lift the taillight cover and remove exposed 2 x Philip screws.  
Remove taillight by pulling rearwards and support taillight in vehicle (harness cannot be disconnected).

Repeat for other side.

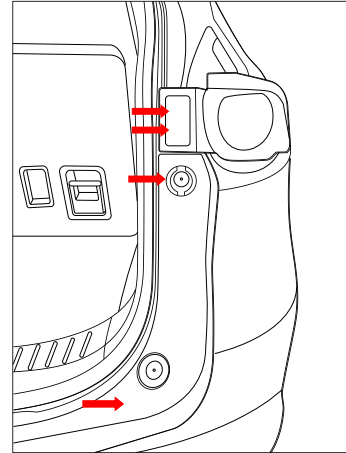

4. In wheel arch remove 3 x scrivets and 1 x clip.

Repeat for other side.

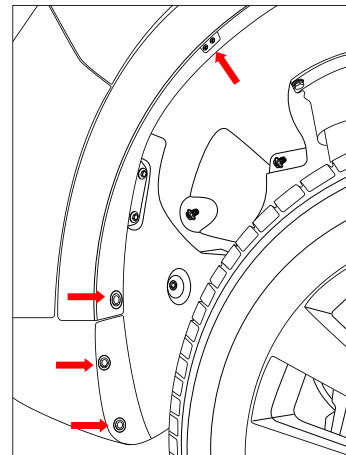

5. Pull wheel arch skirt outwards to reveal 2 x scrivets and 1 x screw.
6. Remove the exposed 2 x scrivets and 1 x screw.
7. Release 2 x clips on bumper.

Repeat for other side.

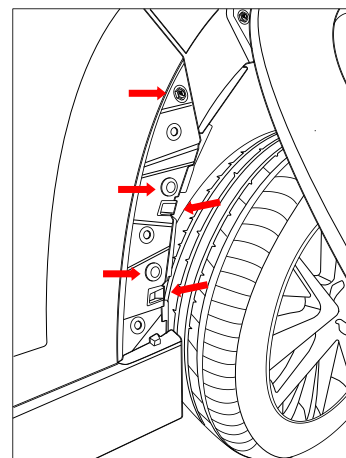



# TOWBAR INSTALLATION INSTRUCTIONS

PART NUMBER 03511RW

MAZDA CX-8 CL4

8. Under vehicle, remove the LH and RH side body trim secured with 2 x screws and 1 x scrivet.
9. Remove 2 x scrivets along bumper.

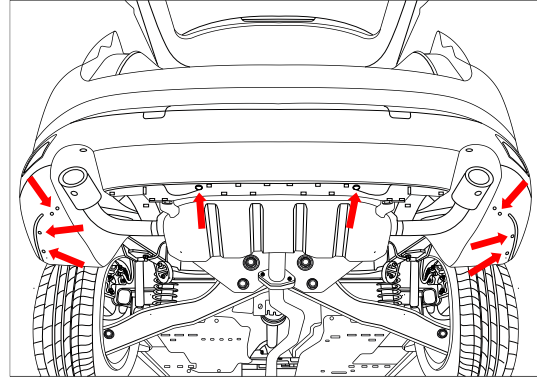

10. Disconnect and remove wiring harness from the vehicle mounting (located inside bumper on the LH side).
11. Peel away bumper from the ends and remove from vehicle.

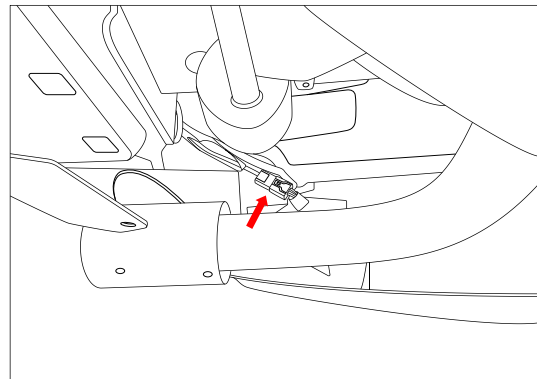

12. Remove and discard the impact beam, secured with 4 x flange nuts per side. Retain the nuts for later use.

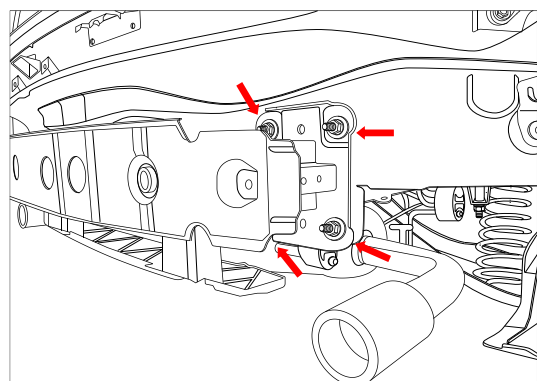



# TOWBAR INSTALLATION INSTRUCTIONS

PART NUMBER 03511RW

MAZDA CX-8 CL4

13. On chassis rail peel off the tape to reveal the 2 x mounting positions.
14. Unclip the wiring harness from the chassis rail.

Repeat for other side.

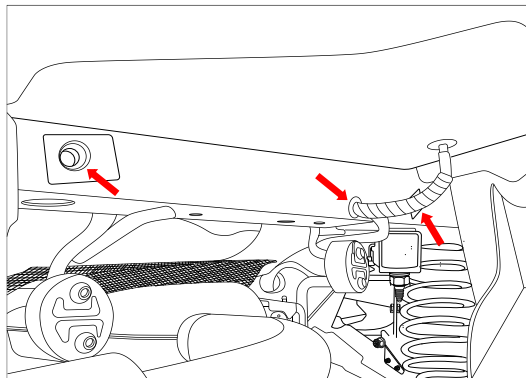

15. Loosely secure side arm to the chassis rail with 2 x M12 bolts complete with 1 x washer per bolt.
16. Cable tie (not provided) the unclipped harness to small hole on the side arm.

Repeat for other side.

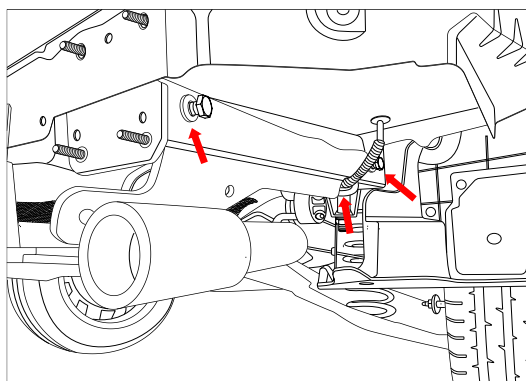

17. Fit the back plates to the impact beam mounting studs and secure with the 4 x retained nuts per side.

**Torque the impact beam nuts to 40Nm.**

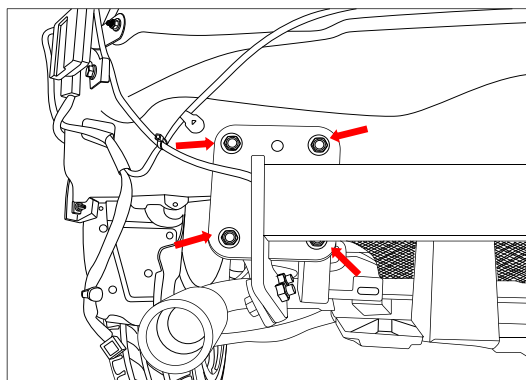



# TOWBAR INSTALLATION INSTRUCTIONS

PART NUMBER 03511RW

MAZDA CX-8 CL4

18. Lift the crosstube to the side arms and loosely secure to the side arms with 3 x M12 Bolts complete with 2 x washers and 1 x nut per bolt for each side.

**Torque all M12 fasteners to 125Nm.**

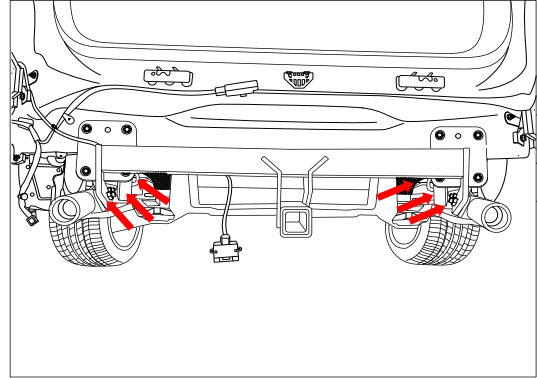

19. For the bumper cut.  
Locate the centre of the bumper, and on the outside, mark off and cut out 90mm wide by 120mm long measured from the bottom edge of the bumper. (Cut should stop about 15mm below the bottom styleline)  
Deburr and smooth off cut edges.

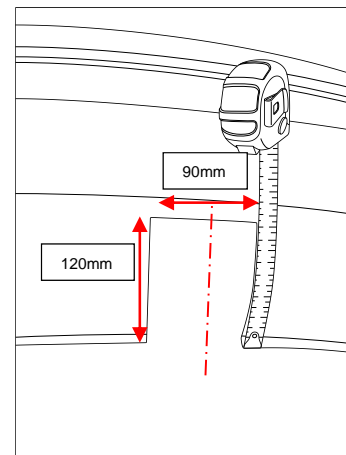

20. Determine an appropriate position for the plug bracket. Mark out and drill 2x  $\varnothing$ 5mm holes 69mm apart on bumper skin to support plug bracket.

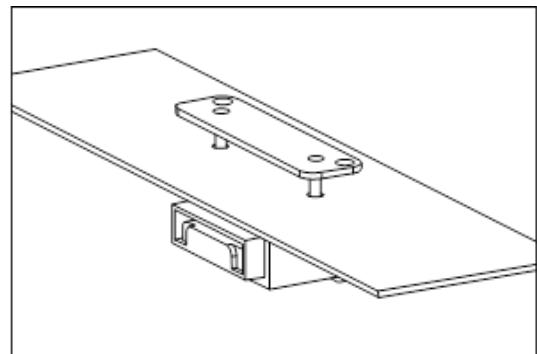

 **IMPORTANT**

Due to possible vehicle variations, always confirm any noted vehicle colour wires with a multi-meter to ensure the correct function is identified before soldering or scotch locking. For vehicle wires denoted with two colours (example; RED/GREEN) the first colour will always be the main wire colour while the second colour is the thinner trace colour on the wire.

21. In the engine bay, disconnect the negative battery (1).

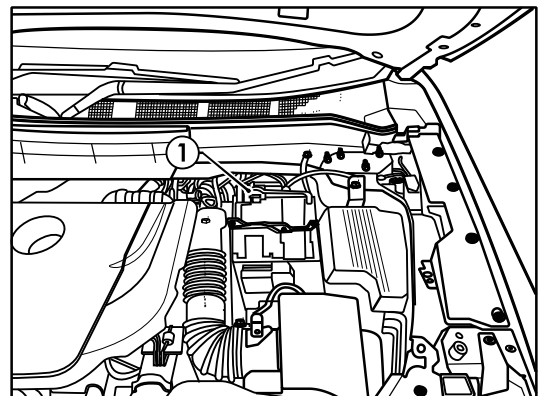

22. In the boot, fold down the third row seats (1).  
23. Remove the centre storage tray cover (2).  
24. Remove the LHS and RHS storage tray covers (3).  
25. Remove the spare wheel cover.  
26. Remove the LHS and RHS tool tray.

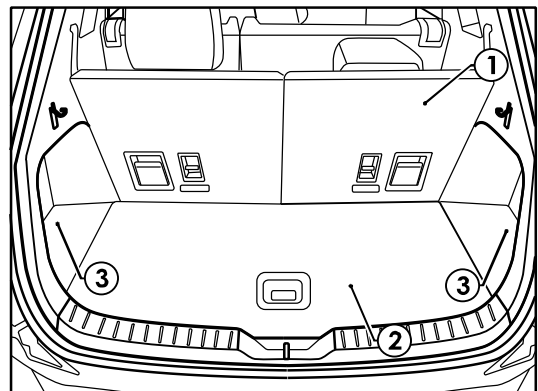

27. On the rear scuff plate (1), use a plastic trim removal tool to pop out the centre of the two clips (2) and remove from scuff plate.
28. Remove the rear scuff plate (1) by pulling in an upwards direction.

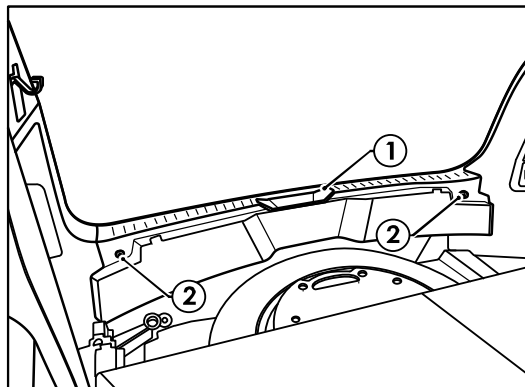

29. Remove the vehicle jack (1).
30. Remove the last tool tray (2).

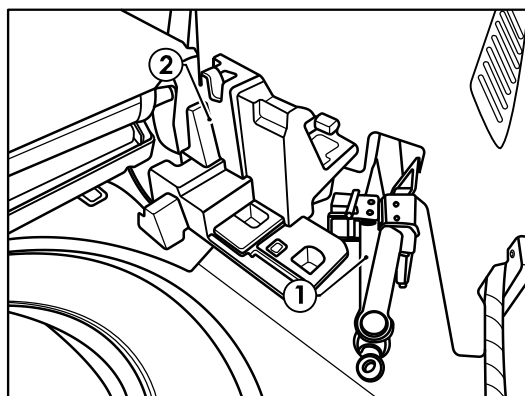

31. On the LHS, remove the trim clip (1) under the previously removed scuff plate.
32. Remove the 10mm bolt behind the 'D' pillar luggage securing hood cover (2).

**Repeat for RHS.**

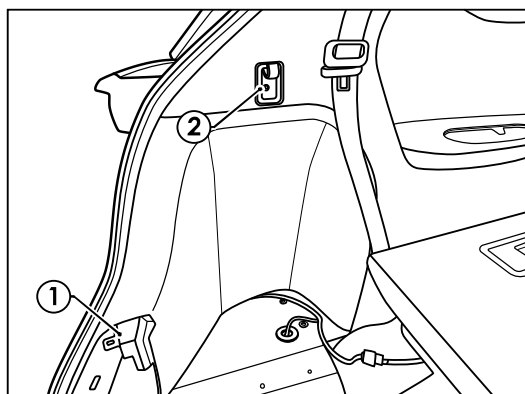



# TOWBAR INSTALLATION INSTRUCTIONS

PART NUMBER 03511RW

MAZDA CX-8 CL4

33. Pop the centre cover (1) off the luggage securing clip (2) near the rear ventilation vent (3).
34. Remove 10mm bolt behind the cover (4).

**Repeat for RHS.**

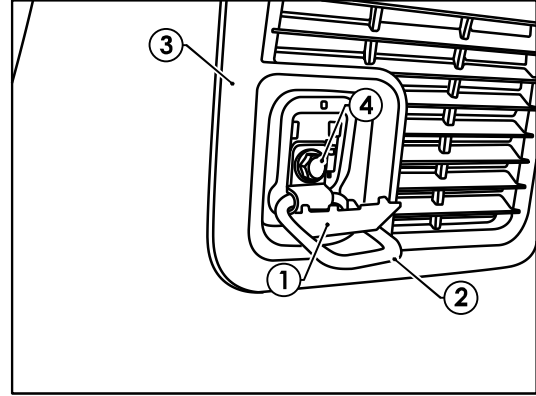

35. Fold LHS trim (1) in towards the centre of the vehicle.
36. Remove the LHS sound deadening carpet (2) enough to gain access to the tail lamp connectors (3).
37. Insert loose terminals on LHS Tail Lamp Patch into LHS Tail Lamp Male and Female Connectors following the pinout diagram and the table for LHS Connector Pinouts.

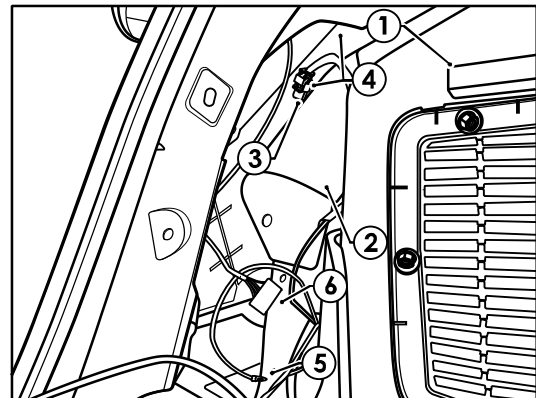

MY2022 – 2023 LHS TAIL LIGHT CONNECTORS		
TERM.	WIRE COLOUR	FUNCTION
1	BN/BK	TAIL
2	YL/BK	L IND
3	RD/BK	STOP
4	GY	-
5	GY/BK	-
5	GY	-

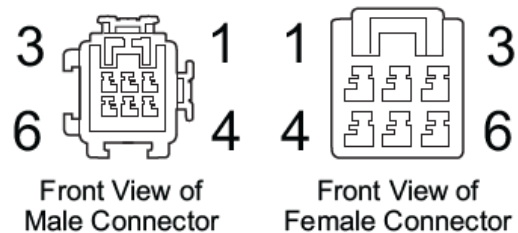

38. Patch in the fully housed LHS Mating Connectors (4) on the Trailer Patch (101257-WL) to the mating LHS Taillight Connectors (3) on the vehicle.
39. Connect the ground wire ring terminal (5) to the vehicle earthing point (6).



# TOWBAR INSTALLATION INSTRUCTIONS

PART NUMBER 03511RW

MAZDA CX-8 CL4

40. Route the T section of the harness along the existing vehicle loom (1) towards the RHS.
41. Fold RHS trim in towards (2) the centre of the vehicle and remove the sound deadening carpet (3) covering the tail lamp connectors.
42. Insert loose terminals on RHS Tail Lamp Patch into RHS Tail Lamp Male and Female Connectors following the pinout diagram and the table for RHS Connector Pinouts.

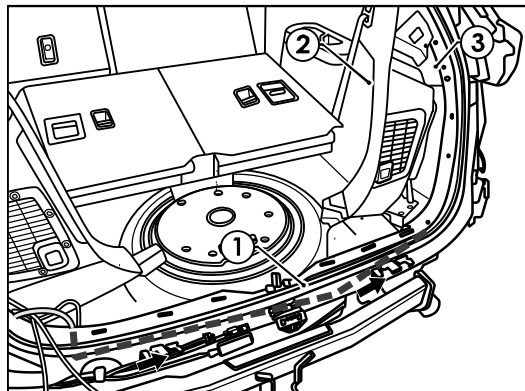

MY2022 – 2023 RHS TAIL LIGHT CONNECTORS		
TERM.	WIRE COLOUR	FUNCTION
1	GY	-
2	GN/BK	R IND
3	GY	-
4	GY/BK	-
5	GY	-
5	GY/BK	-

43. Patch in the fully housed RHS mating connectors on the trailer patch (101257-WL) to the mating RHStail light connectors on the vehicle.

44. On the LHS, using an alcohol wipe, clean the LHS inner sheet metal area (1) and the underside of the ECU (04826) (2).
45. Connect the trailer patch 12-way connector (3) to the ECU (2).
46. Apply double sided tape (4) to the ECU (2) and secure it to the vehicle sheet metal.

**Note: Mount the ECU (2), ensuring the connector (3) is orientated downwards.**

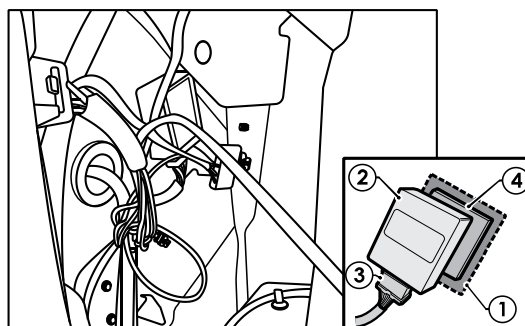



# TOWBAR INSTALLATION INSTRUCTIONS

PART NUMBER 03511RW

MAZDA CX-8 CL4

47. Remove the LHS front (1) and rear (2) passenger scuff trim.
48. Route both the orange power wire and RPA disable patch down the LHS of the vehicle towards the LHS kick panel.

**Note: To avoid entire removal of trim, utilise a guide wire.**

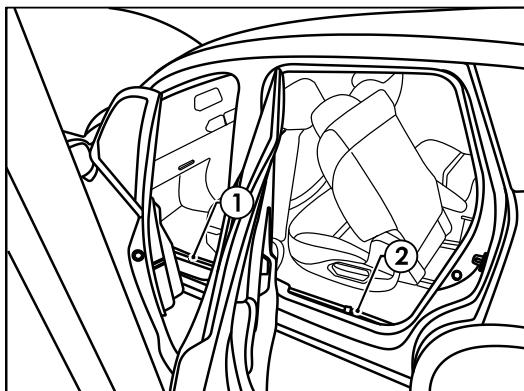

49. In the passenger seat area, remove the kick panel trim (1) by releasing the nut on the firewall (2).

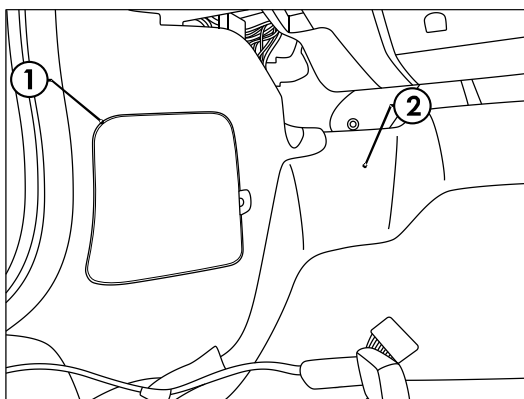

50. With the rear bumper removed, below the LHS tail lamp, locate the 30mm blanking grommet cover and remove.
51. Secure tail harness (Part number: 04944) to tow bar.
52. Route tail harness up through chassis rail and previously removed vehicle blanking grommet.
53. Seat grommet in 30mm blanking hole and route to trailer harness blue connector on wiring loom.

**Note: Keep harness routing clear of all sharp edges, moving parts and places of extreme heat.**

**Note: Ensure grommet is seated correctly and makes a good seal.**

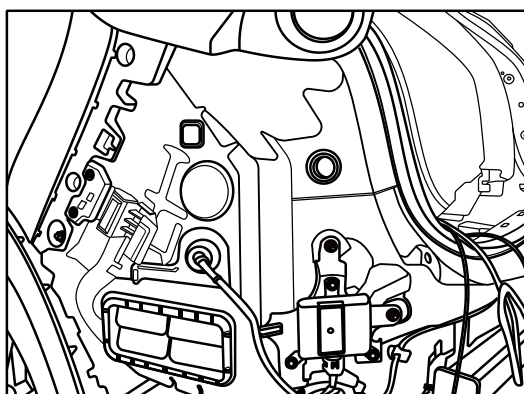

54. Insert the supplied 20 Amp Fuse (1) into the Add-A-Fuse (2) and then insert the Add-A-Fuse (2) into the blank fuse location in the orientation shown.
55. Connect the Add-A-Fuse to the mating connector on the power wire.

**Note: To maintain correct electrical operation, ensure you insert the fuse adaptor into the allocated slot and in the orientation shown.**

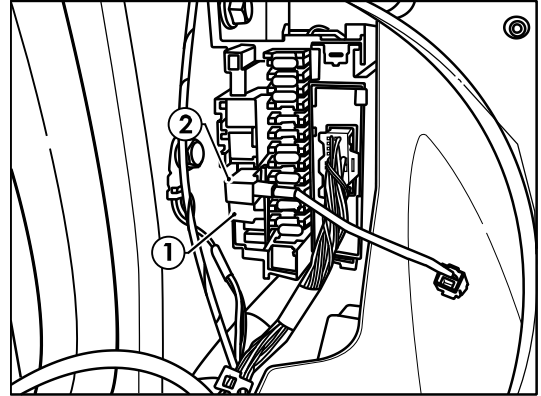

56. Route the Reverse Park Assist disable patch connectors (1) up towards the Parking Assist Module (2) above the glove box.
57. Disconnect the connector from the ECU and patch in the mating T patch connectors (1) into the vehicle ECU (2) and the vehicle harness (3).

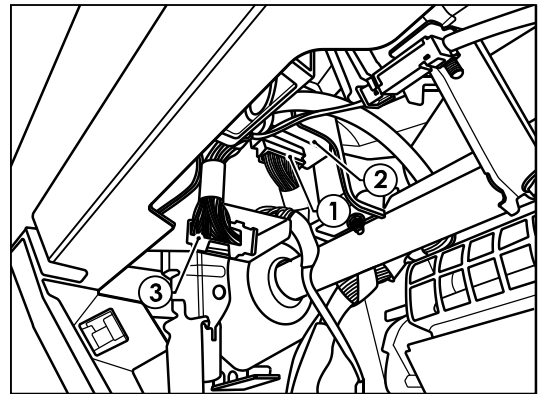

58. Remove the glove box (1) by disconnecting the damping rod (2) and then squeezing both sides (3) to release.

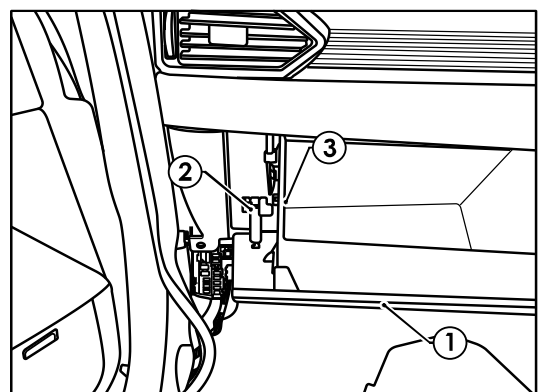



# TOWBAR INSTALLATION INSTRUCTIONS

PART NUMBER 03511RW

MAZDA CX-8 CL4

59. Connect the tail harness 8-way connector (1) to the trailer patch mating 8-way connector (2).
60. Cut-off, crimp the tail harness GREY and GREY/BLACK wires (3) to the trailer patch matching White and GREY/BLACK wires (4).

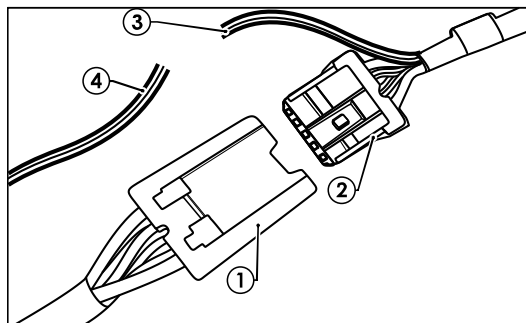

61. Secure all harness using supplied Cable Ties.
62. Test the trailer patch function using a light board or multi-meter.
63. Re-fit all removed parts and secure all fasteners, ensuring there are no squeaks or rattles.
64. Place the fitting instructions in the glove box after fitment.
65. Re-attach bumper and removed components by following steps 1-10 in reverse.



# CUSTOMER INFORMATION

PLACE THESE INSTRUCTIONS IN THE VEHICLE'S GLOVEBOX AFTER INSTALLATION

**THANK YOU FOR PURCHASING HAYMAN REESE.  
WITH CORRECT MAINTENANCE AND CARE THIS PRODUCT WILL PROVIDE A  
LIFETIME OF TROUBLE-FREE OPERATION.**

## TOWBAR MAINTENANCE AND CARE:

1. Hayman Reese recommend that the towbar LUG or TBM (Trailer Ball Mount) Pull Pin and R-clip are removed and stored when not in use. Removal of LUG or TBM (Trailer Ball mount) is advisable when not in use to assist with any of the following.
  - Ensure rear number plate is not obscured.
  - Allow maximum available departure angle and prevent any potential interference.
  - Prevent possible interference with vehicles reverse sensors or camera detecting a tow ball mount as an obstruction during reversing.
  - Removes towball mount as an obstruction for when moving around the rear of the vehicle.
2. Hayman Reese recommends routine inspection of your towbar to ensure trouble free towing.
  - Bolt security and tension should be regularly inspected and checked for correct tension. Replace any worn or defective parts with suitable grade & class fasteners. Inspection should be requested to coincide with vehicle major services.
3. It is the owner's responsibility to ensure towing and down ball weight capacities of the towing vehicle are not exceeded.
  - Towing and down ball weights allowable may differ according to model variations. Please refer to owner's manual or vehicle dealer to confirm exact rating for your vehicle model variant.
  - It is not uncommon for the vehicle tow rating to differ from the towbar rating. When this occurs, the lesser rating must be adhered to.
  - For vehicles fitted with enhanced vehicle functions that may be altered/changed when towing i.e Trailer sway mitigation, blind spot detection, adaptive cruise control etc. Please consult owner's manual to understand changes enabled when towing and after towing.



## WARRANTY INFORMATION:

Hayman Reese Towbars are covered by a Limited Lifetime Warranty.

Our goods come with guarantees that cannot be excluded under the Australian Consumer Law. You are entitled to a replacement or refund for a major failure and for compensation for any other reasonably foreseeable loss or damage. You are also entitled to have the goods repaired or replaced if the goods fail to be of acceptable quality and the failure does not amount to a major failure.

For further details please visit [www.haymanreese.com.au/warranty](http://www.haymanreese.com.au/warranty) or contact customer service on 1800 812 017 or [info@haymanreese.com.au](mailto:info@haymanreese.com.au).



# CUSTOMER INFORMATION

PLACE THESE INSTRUCTIONS IN THE VEHICLE'S GLOVEBOX AFTER INSTALLATION

## HAYMAN REESE SMART PIN

Your Hayman Reese towbar is equipped with Smart Pin technology to help reduce towbar tongue rattle in most driving conditions. Please ensure below instructions are understood and routine maintenance is carried out to ensure best towing experience.

**i** Regularly inspect for wear and check the tightness of the Smart Pin Nut. Follow instructions below to re-tighten the nut as necessary when movement and noise in the tow ball mount is noted.

- Before towing, ensure R-Clip is properly installed and Smart pin nut is installed and tensioned. Replacement parts are available from your Hayman Reese Distributor.

## TOWBALL MOUNT REMOVAL/INSTALLATION

### STEP 1

Insert Trailer Ball Mount (TBM) (a) into towbar hitchbox (b), aligning hole in TBM shank (c) with hole in hitchbox (d) (Fig. 1)

### STEP 2

Insert Smart Pin (e) through hole in hitchbox and hole in TBM shank (g); ensure the locators are inserted into the notches in the hitchbox (Fig. 2)

### STEP 3

Screw Smart Pin Nut (f) onto Smart Pin (g); tighten Smart Pin Nut until finger tight, ensuring TBM is restrained from up and down movement.

### STEP 4

Tighten Smart Pin Nut by turning nut a further 1/8th of a turn in the clockwise direction using a 24mm spanner (Fig. 4).

### STEP 5

Install Smart Pin R-Clip through the hole that provides best clearance or easiest access. (Fig. 5)

### STEP 6

Install towball onto TBM and tighten to **350 Nm** using a calibrated torque wrench (Fig. 6).

