



# TOWBAR INSTALLATION INSTRUCTIONS

PART NUMBER 03510RW

MAZDA 6 GL SEDAN CL4



## PRODUCT DETAILS:

Part Number:	03510RW	Maximum Towing Braked:	1600	kg
ECU Number:	04826	Maximum Towing Unbraked:	550	kg
Tail Harness Length Required:	1800 mm	Maximum Static Ball Load:	120	kg
TBM/Lug Part Number:	21320			
Wiring Part Number:	101257-WL			

## FITTING DETAILS:

Towbar Installation Time:	105 Mins.	Vehicle Coding Required:	NO
Wiring Installation Time:	60 Mins.	RPA Disable/Other:	YES
Total Installation Time:	165 Mins.	Note:	
Bumper Cut Required:	Yes		

- RPA Disable use Part No. 04944
- Bumper cut required on underside of bumper bar.
- Electric brake input wire near blue connector.



# TOWBAR INSTALLATION INSTRUCTIONS

PART NUMBER 03510RW

MAZDA 6 GL SEDAN CL4

**ENSURE THAT INSTRUCTIONS ARE UNDERSTOOD PRIOR TO FITMENT.**

## **i** BEFORE YOU START:

Hayman Reese recommends that instructions are read completely prior to fitment. Check all hardware items have been included refer to assembly diagram. Please ensure this towbar is only fitted to vehicle models as per Hayman Reese application guide ([www.haymanreese.com.au](http://www.haymanreese.com.au)).

### Bumper Cuts



Vehicle and bumper variations can and do occur during vehicle manufacture after initial towbar design. Fitment of towbar to vehicle and accuracy of bumper cut must be assessed prior to any bumper modifications made. Incorrect bumper cuts are not covered under Hayman Reese warranty.

**NOTE: Bumper cuts need to be approached with care, refer to notes below.**

- Bumper centreline – where the centreline of the bumper needs to be determined, the installer must assess centre point by measurement of bumper width or determining two symmetrical reference points to give centreline.
- Bumper edge – To assist with accurate bumper cut measurement, reference to the start of the bumper edge is now being commonly used.
  - Measure from bottom edge along bumper and around corner to the 70 mm point (Figure 1).
  - Do not measure from visible bumper front of corner, upwards (Figure 2).

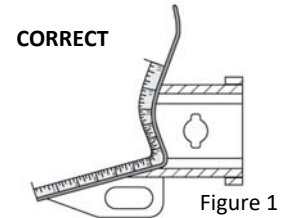

Figure 1

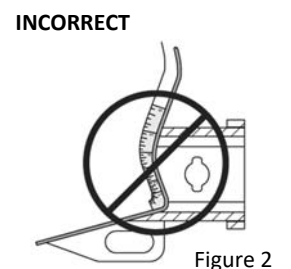

Figure 2

### Drilling

- For any required drilling during installation, ensure that the area is clear of fuel, electrical & other components that may be damaged.
- All holes drilled into the body panels shall have all burrs & swarf removed then coated with a suitable rust preventative paint.

### Bolts/Fasteners

- Ensure that all hardware is fastened to correct torque as specified in this fitting instruction.
- All fasteners supplied with this product are used to achieve a specified clamp loading. If replacement is required ensure that fasteners of the same grade and class are used.



**NOTE: Achieving correct torque is critical to proper installation and responsibility of the installer. Towbar failures attributed to tension issues from over tightening or under tightening are not covered by Hayman Reese warranty.**

### Product Labels

- a. Towbar load rating sticker provided with this product shall be conspicuously located on inside rear end of the driver's door.
- b. Powertrain Control Module (PCM)/Body Control Module (BCM) upgrade warning label will be provided in towbar kit for vehicles as required. Affix warning label in door and owner's handbook.

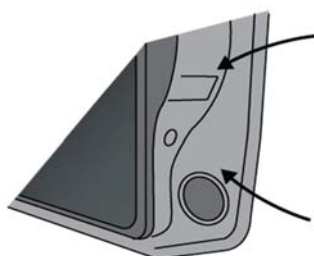

Place **Load Rating sticker** inside driver's door here

Place **Vehicle PCM/ BCM upgrade warning label** in door AND on front cover of owner's service handbook

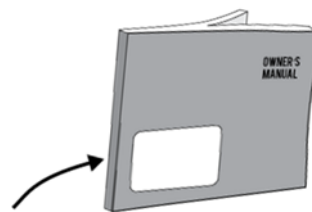

## **WARNING:**

**Do not, drill, cut, weld or otherwise modify the towbar. FOR TOWING PURPOSES ONLY - This towbar is designed and tested by Hayman Reese to adhere to ADR 62/02 which provides only for the expected load demands of towing.**



# TOWBAR INSTALLATION INSTRUCTIONS

PART NUMBER 03510RW

MAZDA 6 GL SEDAN CL4

## **i** TOWBAR ASSEMBLY DIAGRAM

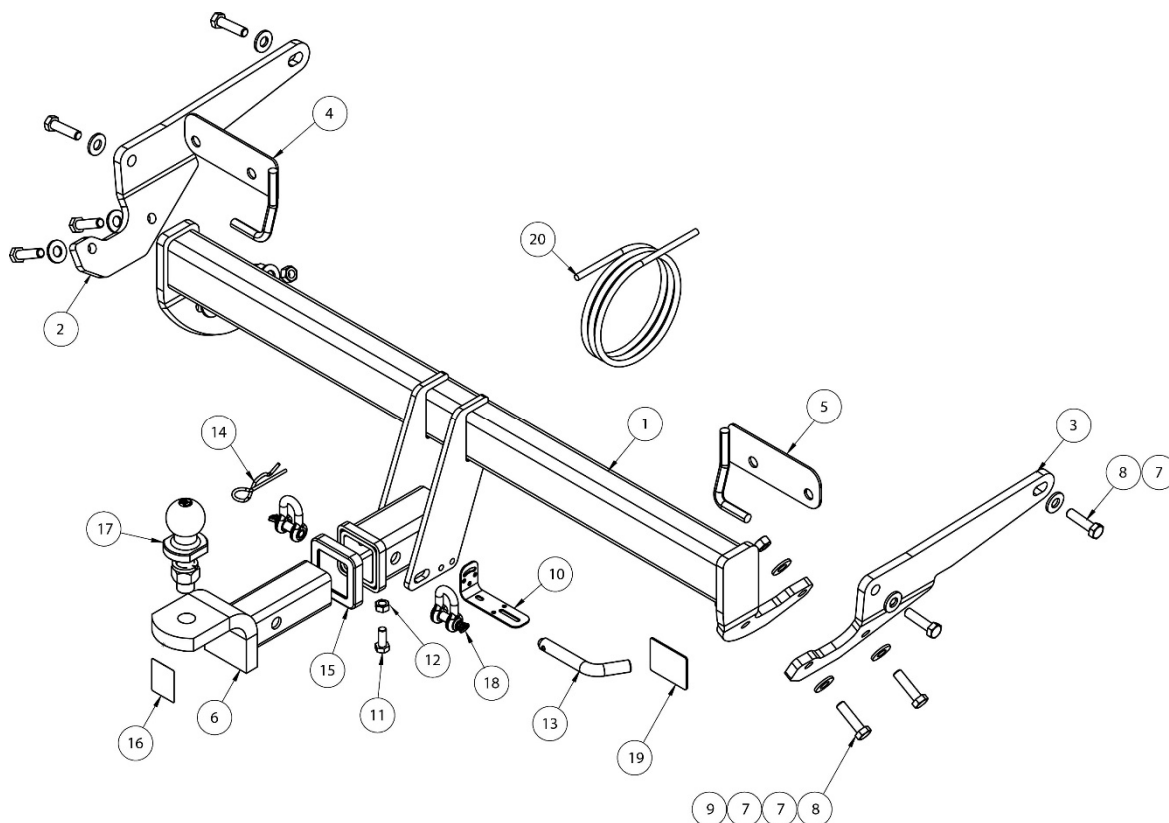

ITEM	DESCRIPTION	QTY
1	CENTRE SECTION WELDED ASSY	1
2	SIDE ARM LHS	1
3	SIDE ARM RHS	1
4	LHS EXHAUST HANGER	1
5	RHS EXHAUST HANGER	1
6	TRAILER BALL MOUNT	1
7	WASHER PLAIN M12x28x2.5mm	12
8	SET SCREW HEX HD M12x45x1.25P	8
9	NUT HEX M12x1.25P	4
10	UNIVERSAL PLUG BRACKET KIT	1

ITEM	DESCRIPTION	QTY
11	BOLT HEX HD M10x25x1.5P	1
12	NUT HEX M10x1.5P	1
13	PULL PIN	1
14	SPRING COTTER PIN	1
15	HITCH BOX COLLAR COVER	1
16	HAYMAN REESE LOGO STICKER	1
17	TOWBALL 50mm	1
18	10mm "D" SHACKLE	2
19	COMPLIANCE LABEL	1
20	WIRING LOOM	1



# TOWBAR INSTALLATION INSTRUCTIONS

PART NUMBER 03510RW

MAZDA 6 GL SEDAN CL4

1. Remove 2 x screws and 1 x push rivet inside Rear wheel arch.

Repeat for other side

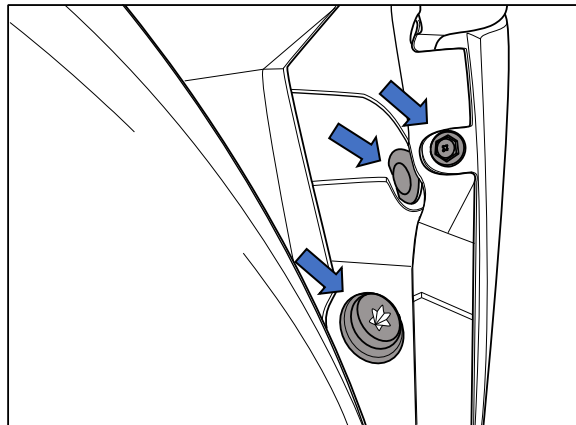

2. On the underside of bumper to back panel remove 2 x push rivets securing the bumper to the back Panel.

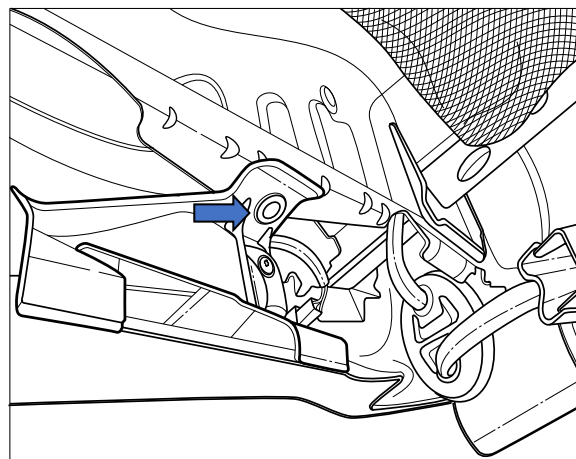

3. Open boot, remove inner carpet and polystyrene Inserts. Remove 4 x push rivets 2 each side attaching inner plastic trim to rearwards face of inside boot cavity.

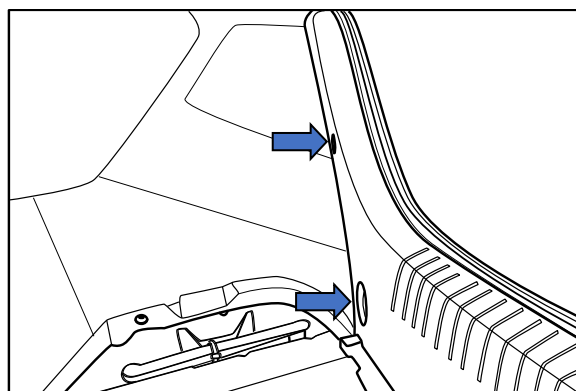



# TOWBAR INSTALLATION INSTRUCTIONS

PART NUMBER 03510RW

MAZDA 6 GL SEDAN CL4

4. Unclip plastic trim around locking latch.
5. Remove inner plastic trim by lifting upwards.

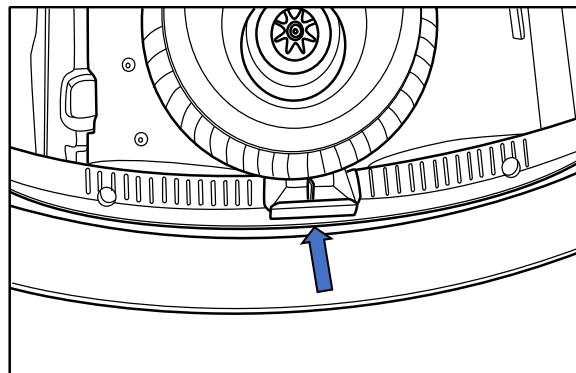

6. Remove 2 x small plastic push rivets in newly exposed area securing inside carpet to chassis rail.

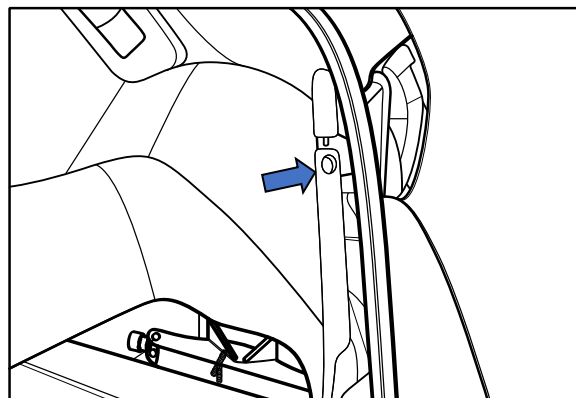

7. From underneath loosened carpet remove 3 x nuts from rear of taillight and remove light assembly.

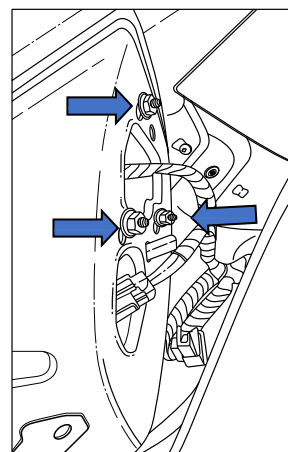



# TOWBAR INSTALLATION INSTRUCTIONS

PART NUMBER 03510RW

MAZDA 6 GL SEDAN CL4

8. In newly exposed cavities from taillights remove 1 x screw each side on rear face of bumper, remove cover cap and remove screw securing bumper underneath.

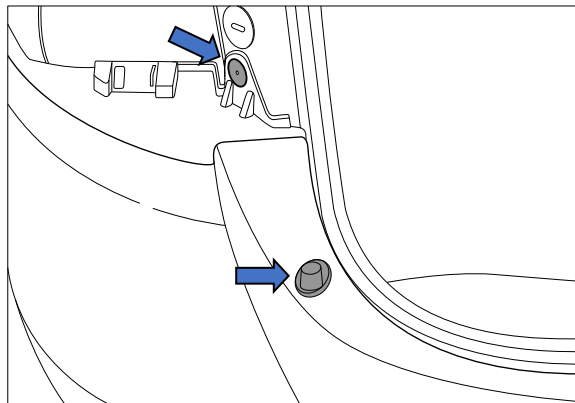

9. Remove 2 x screws from underside of bumper on both sides.
10. Unclip the sides of the bumper by pulling firmly and remove bumper.

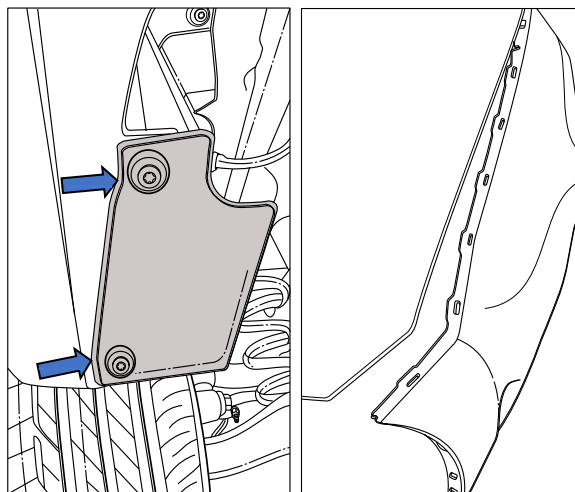

11. Disconnect both exhaust hanger rubbers from rear impact beam.

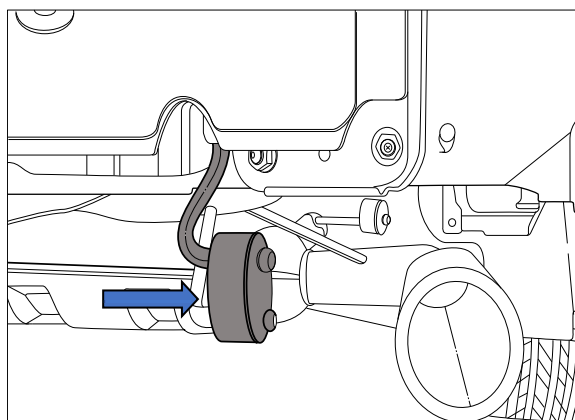



# TOWBAR INSTALLATION INSTRUCTIONS

PART NUMBER 03510RW

MAZDA 6 GL SEDAN CL4

- 
12. Remove rear impact beam from vehicle by removing 8 x nuts securing beam to chassis discard the beam after removal.

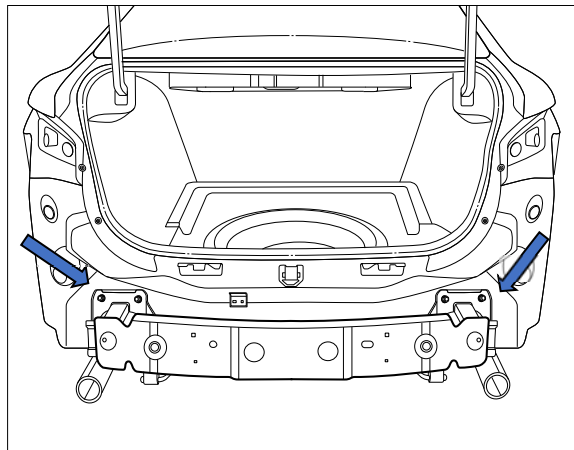

- 
13. Secure supplied exhaust hanger plates to chassis using existing bolts mounting to the lower studs.  
14. Attach exhaust hanger rubbers to the hooks on each newly mounted plate.

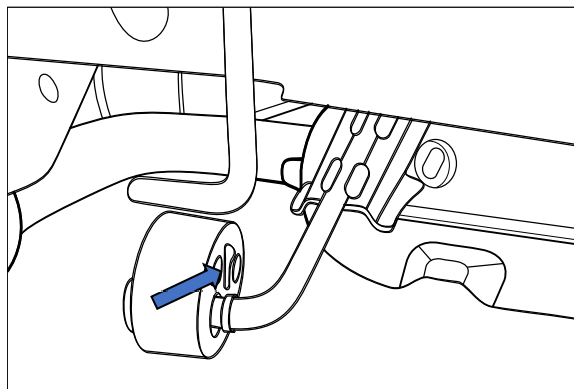

- 
15. Loosely bolt side arms to chassis rail using 2 x M12 bolts & washers on both sides.

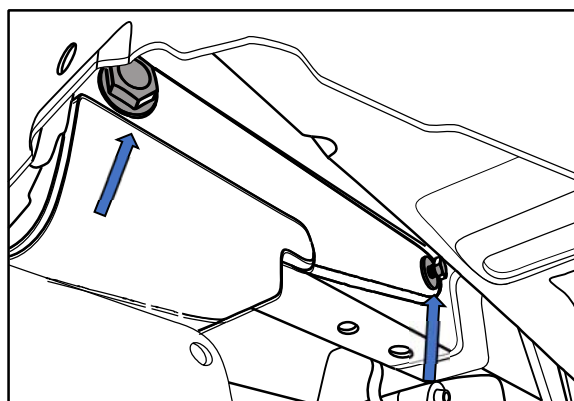



# TOWBAR INSTALLATION INSTRUCTIONS

PART NUMBER 03510RW

MAZDA 6 GL SEDAN CL4

16. Mount towbar centre section to chassis arms ensuring that bolts are directed inward as to allow for bumper clearance complete with 2 washers and 1 nut per bolt.

17. Torque fasteners to list below.

- M12 x 45 x 1.25P 89 N.m
- M12 x 1.25P Nut 89 N .m

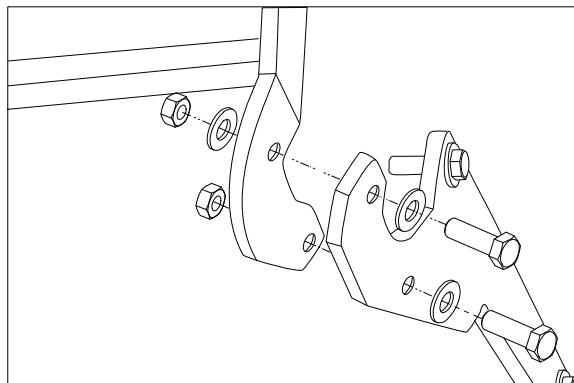

18. Cut out section of bumper under tray approximately 175mm x 90mm as shown.

19. Re-fit the bumper and all other components following steps 1 through 9 in reverse order.

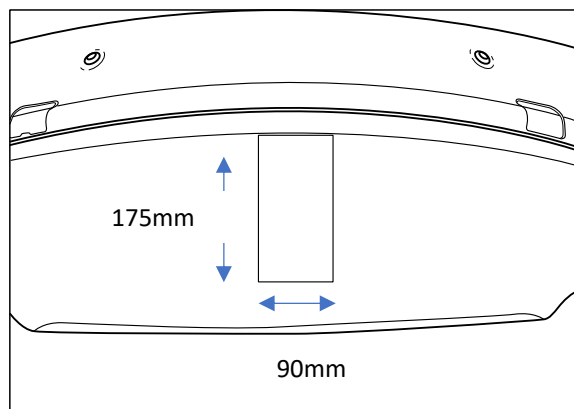



# TOWBAR INSTALLATION INSTRUCTIONS

PART NUMBER 03510RW

MAZDA 6 GL SEDAN CL4

## IMPORTANT

Due to possible vehicle variations, always confirm any noted vehicle colour wires with a multi-meter to ensure the correct function is identified before soldering or scotch locking. For vehicle wires denoted with two colours (example; RED/GREEN) the first colour will always be the main wire colour while the second colour is the thinner trace colour on the wire.

20. In the engine bay, disconnect the negative battery (1).

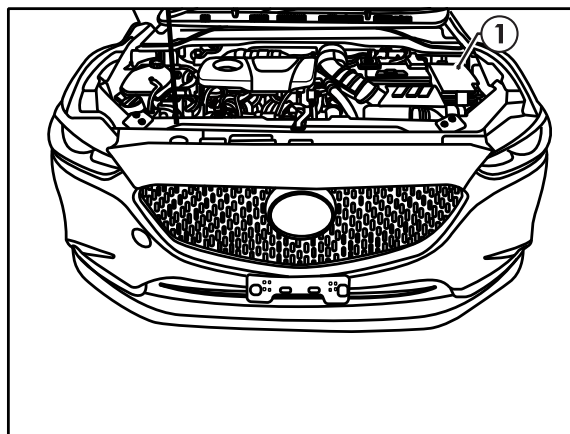

21. In the boot, remove the carpet floor (1).  
22. Remove the tool storage tray.  
23. Remove the LHS and RHS storage trays.  
24. Fold down the third row seats (2) by pulling the levers (3).  
25. Remove the rear scuff plate by first popping out the centre of the four clips and then pulling in an upwards direction.

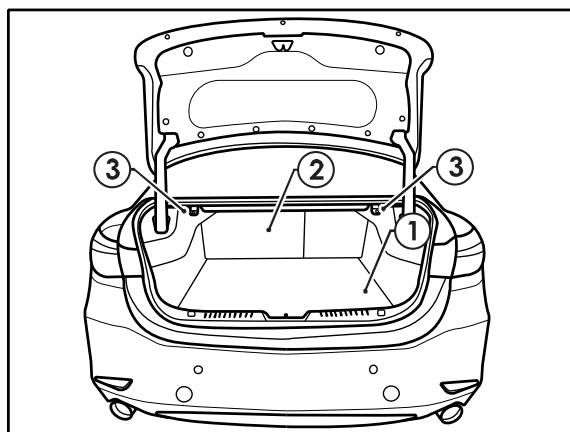

26. On the RHS, remove the trim clips (1) on the RHS boot trim (2).
27. Fold the trim inwards to gain access to the tail light connectors.

**Repeat for LHS.**

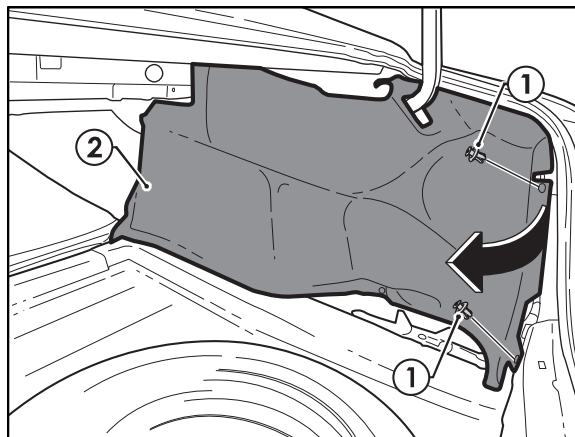

28. On the LHS, remove the Front and Rear passengers scuff trim (1).

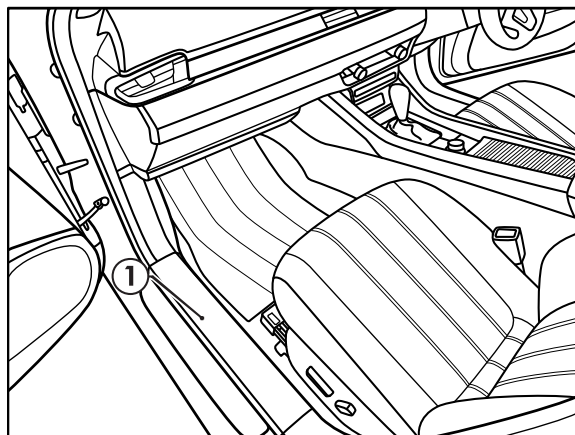

29. From the front Passenger seat, unclip the dampers (1) on the glove box.
30. Squeeze both sides of the glovebox simultaneously to release from the stops.
31. Let the glove box fall below the stops and then pull to release from the vehicle.
32. Dislodge the trim under the glovebox (2).
33. Disconnect the footlight connector and remove the trim under the glove box from the vehicle.
34. Remove the LHS passenger kick panel trim (3).

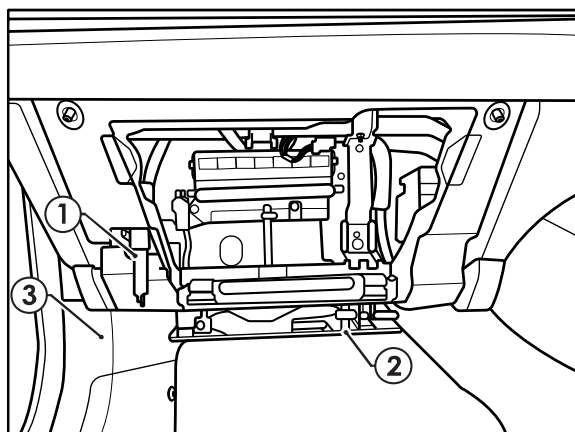



# TOWBAR INSTALLATION INSTRUCTIONS

PART NUMBER 03510RW

MAZDA 6 GL SEDAN CL4

35. Insert loose terminals on RHS Tail Lamp Patch into RHS Tail Lamp Male and Female Connectors following the pinout diagram and the table for RHS Connector

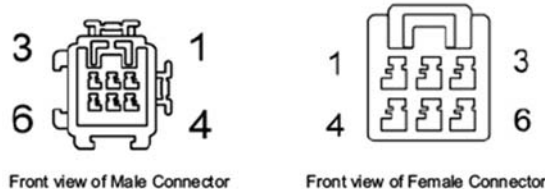

MAZDA 6 SEDAN RHS TAIL LIGHT CONNECTORS		
TERM.	WIRE COLOUR	FUNCTION
1	GN/BK	R. IND
2	GY	-
3	GY	-
4	GY/BK	-
5	GY	-
6	GY/BK	-

36. At Patch in the fully housed RHS mating connectors (1) on the trailer patch (101257-WL) to the mating RHS tail light connectors (2) on the vehicle.

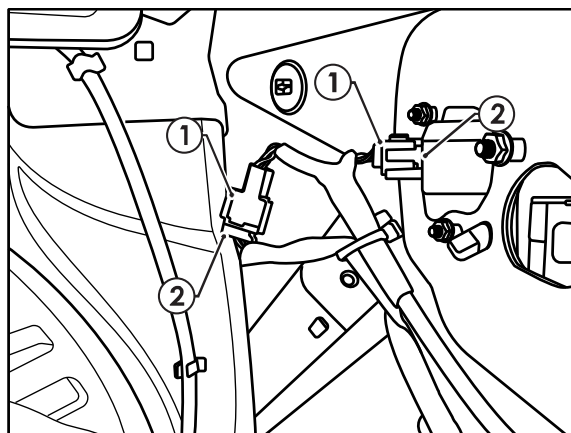

37. Route the harness across to the LHS towards the tail lamp.  
38. Insert terminals on LHS Tail Lamp Patch into LHS Tail Lamp Male and Female Connectors following the pinout diagram and the table for LHS Connector Pinouts.

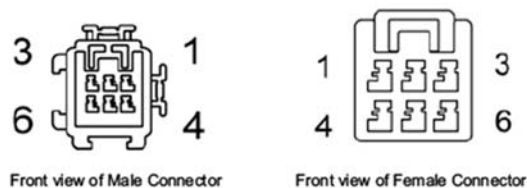

MAZDA 6 SEDAN LHS TAIL LIGHT CONNECTORS		
TERM.	WIRE COLOUR	FUNCTION
1	YL/BK	L. IND
2	BN/BK	TAIL
3	GY	-
4	RD/BK	STOP
5	GY/BK	-
6	GY	-



# TOWBAR INSTALLATION INSTRUCTIONS

PART NUMBER 03510RW

MAZDA 6 GL SEDAN CL4

39. Patch in the fully housed LHS mating connectors (1) on the trailer patch to the mating LHS tail light connectors (2) on the vehicle.

40. Connect the ground wire ring terminal (3) to the vehicle earthing point (4).

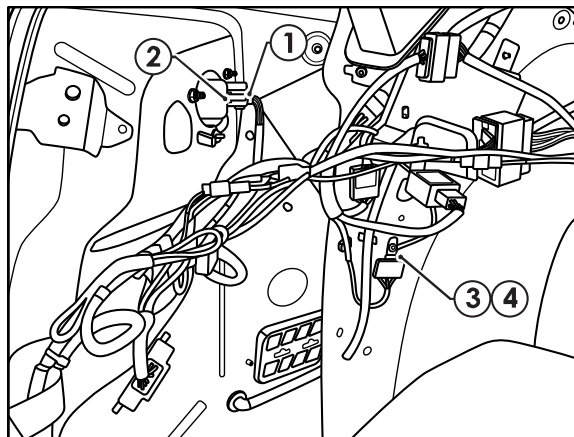

41. Using an alcohol wipe, clean the LHS inner sheet metal area (1) and the underside of the ECU (04826) (2).

42. Connect the trailer patch 12-way connector (3) to the ECU (2).

43. Apply double sided tape to the ECU (2) and secure it to the vehicle sheet metal.

**Note: Mount the ECU, ensuring the connector is orientated downwards.**

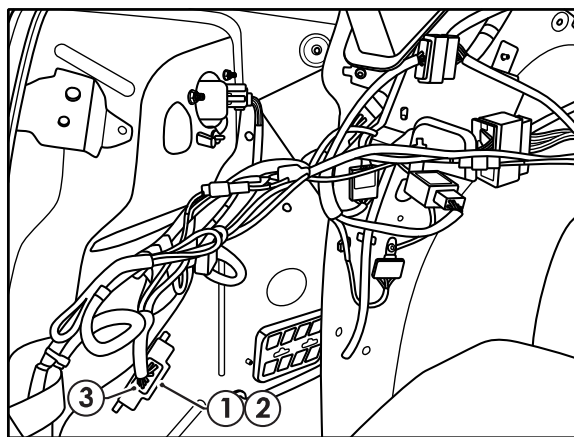

44. Route both the orange power wire (1) and RPA disable patch (2) down the LHS of the vehicle towards the LHS kick panel.

**NB: to avoid entire removal of trim, utilise a guide wire.**

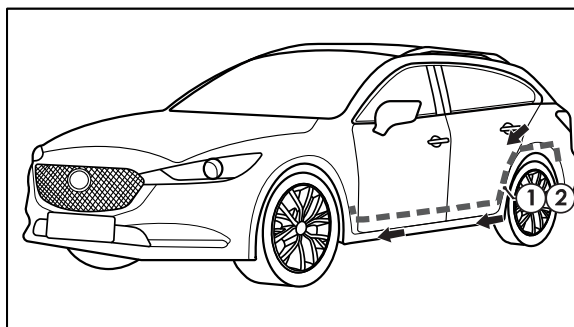



# TOWBAR INSTALLATION INSTRUCTIONS

PART NUMBER 03510RW

MAZDA 6 GL SEDAN CL4

45. At the Fuse box Insert the supplied 20 amp fuses (1) into the Add-A-Fuse (2) and then insert the Add-A-Fuse (2) into the fuse position 3 blank fuse location in the orientation shown.

46. Connect the Add-A-Fuse (2) to the mating connector on the power wire.

**Note: To maintain correct electrical operation, ensure you insert the fuse adaptor into the allocated slot and in the orientation shown.**

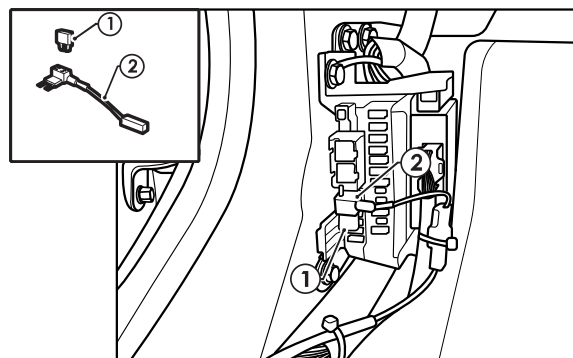

47. Route the Reverse Park Assist disable patch connectors up towards the Parking Assist Module (1) above the glovebox.

48. Disconnect the connector from the ECU and patch in the mating T patch connectors (2) into the vehicle ECU and the Vehicle harness.

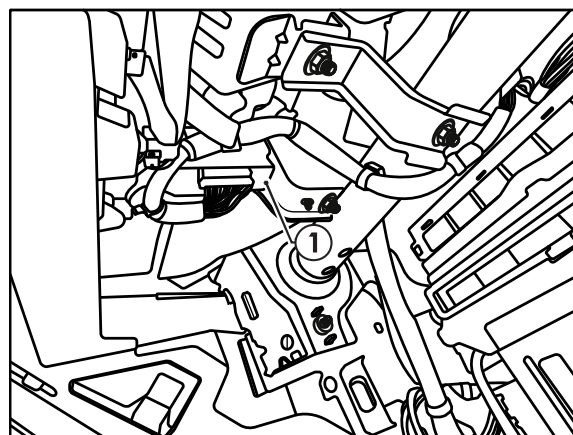

49. Locate a suitable area on the LHS floor to drill a 30mm hole to enable the tail harness to be routed from the ECU to the towbar.

50. Secure tail harness to towbar. Route tail harness up through chassis and previously drilled grommet hole.

51. Seat grommet in 30mm blanking hole and route to trailer harness blue connector on patch loom

**Note: Keep harness routing clear of all sharp edges, moving parts and places of extreme heat.**

**Note: Ensure grommet is seated correctly and makes a good seal.**

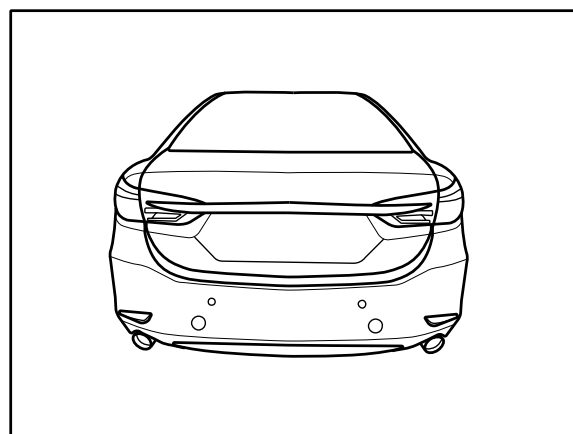



# TOWBAR INSTALLATION INSTRUCTIONS

PART NUMBER 03510RW

MAZDA 6 GL SEDAN CL4

- 
52. Connect the tail harness (part number 04944) 8-way connector (1) to the trailer patch mating 8-way connector (2).
  53. Cut-off, crimp the tail harness GREY and GREY/BLACK wires (3) to the trailer patch matching GREY and GREY/BLACK wires (4).

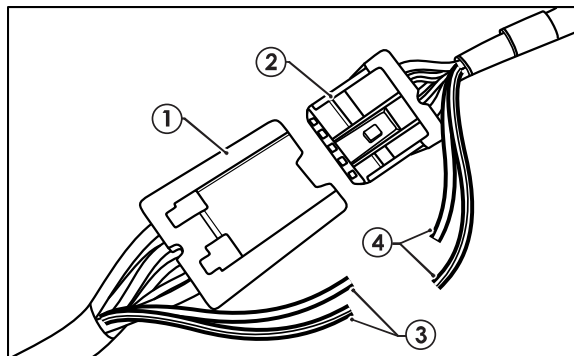

- 
54. Secure all harness using supplied cable ties.
  55. Test the trailer patch function using a light board or multi-meter.
  56. Re-fit all removed parts and secure all fasteners, ensuring there are no squeaks or rattles.
  57. Place the fitting instructions in the glove box after fitment.
-



# CUSTOMER INFORMATION

PLACE THESE INSTRUCTIONS IN THE  
VEHICLE'S GLOVEBOX AFTER INSTALLATION

**THANK YOU FOR PURCHASING HAYMAN REESE.  
WITH CORRECT MAINTENANCE AND CARE THIS PRODUCT WILL PROVIDE A  
LIFETIME OF TROUBLE-FREE OPERATION.**

## **i** TOWBAR MAINTENANCE AND CARE:

1. Hayman Reese recommend that the towbar LUG or TBM (tow ball Mount) Pull Pin and R-clip are removed and stored when not in use. Removal of LUG or TBM (tow ball mount) is advisable when not in use to assist with any of the following.
  - Ensure rear number plate is not obscured.
  - Allow maximum available departure angle and prevent any potential interference.
  - Prevent possible interference with vehicles reverse sensors or camera detecting a tow ball mount as an obstruction during reversing.
  - Removes tow ball mount as an obstruction for when moving around the rear of the vehicle.
2. Hayman Reese recommends routine inspection of your towbar to ensure trouble free towing.
  - Bolt security and tension should be regularly inspected and checked for correct tension. Replace any worn or defective parts with suitable grade & class fasteners. Inspection should be requested to coincide with vehicle major services.
3. It is the owner's responsibility to ensure towing and down ball weight capacities of the towing vehicle are not exceeded.
  - Towing and down ball weights allowable may differ according to model variations. Please refer to owner's manual or vehicle dealer to confirm exact rating for your vehicle model variant.
  - It is not uncommon for the vehicle tow rating to differ from the towbar rating. When this occurs, the lesser rating must be adhered to.
  - For vehicles fitted with enhanced vehicle functions that may be altered/changed when towing i.e. Trailer sway mitigation, blind spot detection, adaptive cruise control etc. Please consult owner's manual to understand changes enabled when towing and after towing.

## **i** WARRANTY INFORMATION:

Hayman Reese Towbars are covered by a Lifetime Warranty.

Our goods come with guarantees that cannot be excluded under the Australian Consumer Law. You are entitled to a replacement or refund for a major failure and for compensation for any other reasonably foreseeable loss or damage. You are also entitled to have the goods repaired or replaced if the goods fail to be of acceptable quality and the failure does not amount to a major failure.

For further details please visit [www.haymanreese.com.au/warranty](http://www.haymanreese.com.au/warranty) or contact customer service on 1800 812 017 or [info@haymanreese.com.au](mailto:info@haymanreese.com.au).



# CUSTOMER INFORMATION

PLACE THESE INSTRUCTIONS IN THE VEHICLE'S GLOVEBOX AFTER INSTALLATION

## HAYMAN REESE SMART PIN

Your Hayman Reese towbar is equipped with Smart Pin technology to help reduce towbar tongue rattle in most driving conditions. Please ensure below instructions are understood and routine maintenance is carried out to ensure best towing experience.

**i** Regularly inspect for wear and check the tightness of the Smart Pin Nut. Follow instructions below to re-tighten the nut as necessary when movement and noise in the tow ball mount is noted.

- Before towing, ensure R-Clip is properly installed and Smart pin nut is installed and tensioned. Replacement parts are available from your Hayman Reese Distributor.

## TOWBALL MOUNT REMOVAL/INSTALLATION

### STEP 1

Insert Trailer Ball Mount (TBM) (a) into towbar hitchbox (b), aligning hole in TBM shank (c) with hole in hitchbox (d) (Fig. 1)

### STEP 2

Insert Smart Pin (e) through hole in hitchbox and hole in TBM shank (g); ensure the locators are inserted into the notches in the hitchbox (Fig. 2)

### STEP 3

Screw Smart Pin Nut (f) onto Smart Pin (g); tighten Smart Pin Nut until finger tight, ensuring TBM is restrained from up and down movement.

### STEP 4

Tighten Smart Pin Nut by turning nut a further 1/8th of a turn in the clockwise direction using a 24mm spanner (Fig. 4).

### STEP 5

Install Smart Pin R-Clip through the hole that provides best clearance or easiest access. (Fig. 5)

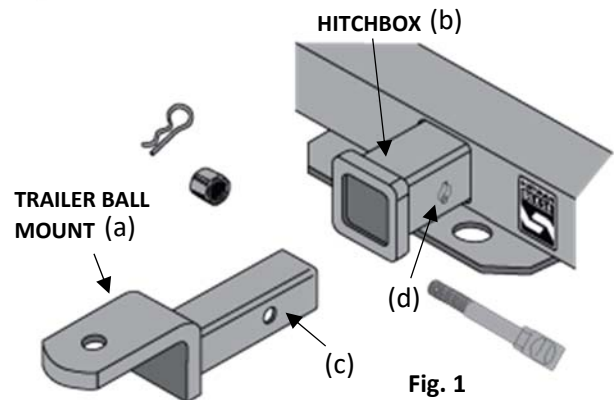

Fig. 1

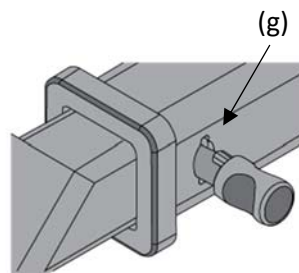

Fig. 2

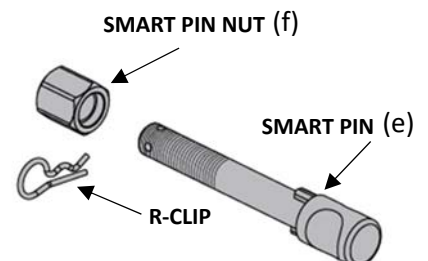

Fig. 3

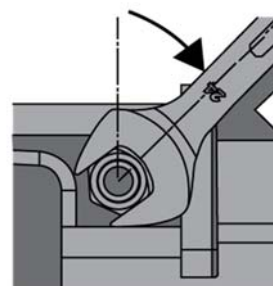

Fig. 4

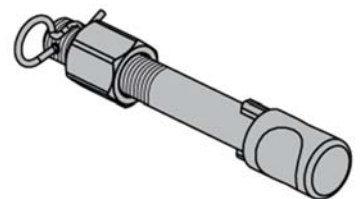

Fig. 5