

INSTALLATION INSTRUCTIONS



2479-TO SUIT HONDA ACCORD 02-2008-ON
ENSURE INSTRUCTIONS ARE UNDERSTOOD BEFORE INSTALLATION.

Rating Braked 1200 Kg
Rating Unbraked 500 Kg
Max Static Ball Load 60 Kg

Warning:

1. Do not, drill, cut, weld or otherwise modify the towbar.
2. If you are using electric welding on a motor vehicle, **always** check that the vehicle is not equipped with electronic engine or instrument management equipment. Failure to do so could **destroy** any onboard computers. If in doubt, check with the vehicle's manufacturer.

1. **General:** Ensure all hardware items have been included refer to assembly diagram.
2. It is recommended that the instructions are read through and completely understood before making any attempt to fit this product.
3. Be wary of any changes to vehicle designs or other accessories that may conflict with the installation of this product.
4. Before drilling ensure that the area is clear of fuel, electrical & other components.
5. All holes drilled into the body panels shall have all burrs & swarf removed then coated with a suitable rust preventative paint.
6. The high tensile fasteners supplied with this product were used to achieve the specified rating. If replacement is required ensure that fasteners of the same rating & quality are used. Contact an authorised **Hayman Reese** dealer if further information is required.
7. Ensure that all hardware is fastened to torque list below check fasteners on regular basis.
8. Towbar load rating sticker provided with this product shall be conspicuously located on inside rear end of the driver's door. **(See diagram below).**
9. Hayman Reese recommends that you check your tow ball to ensure that it complies with the Australian standards **AS 4177.2**.
10. **PLEASE NOTE:** It is advised to remove your lug or tbn when not actually towing so as to produce a clear view of the vehicles registration plate if obscured, and to also provide maximum available departure angle.

Tow bar Maintenance and Care.

Hayman Reese recommends that bolt torque's, as listed below, are routinely and regularly inspected and checked for correct tension. Replace any worn or defective parts.

We recommended to remove Tow Ball Mounts (TBM's, tongues or lugs) when not being used for any considerable length of time.

So as to avoid injury, when not towing it is suggested that the tongue, Pull Pin and R-clip are removed then stored in a safe, clean and dry place, away from excessive moisture.

Hitch Pull Pins and spring "R" clips are regularly checked for proper installation. Replace any worn or defective parts.

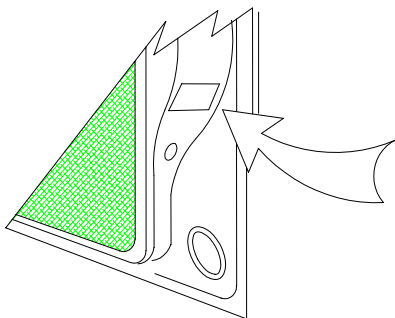

Place load rating sticker
inside driver's door here

RECOMMENDED ASSEMBLY TORQUE LISTING

Diameter Grade 8.8 Bolt

M6	9.5 Nm
M8	21.7 Nm
M10	43.4 Nm
M12	77.3 Nm
M16	189.8 Nm

FOR TOWING PURPOSES ONLY

For towing capacity details please refer to vehicle owner's manual or to the manufacturer. Overloading can void your warranties.

INSTALLATION INSTRUCTIONS



2479-TO SUIT HONDA ACCORD 02-2008-ON

ENSURE INSTRUCTIONS ARE UNDERSTOOD BEFORE INSTALLATION.

11. Remove rear bumper bar skin via

- Remove 3 x screws from each inner wheel arch see fig 1.
- Remove 2 x plastic trim plugs from underside of the bumper bar skin see fig 2.
- Remove 2 x plastic covers inside the rear boot cavity to expose 2 x M8 bolts see fig 3.
- Remove 2x M8 bolts from rear boot cavity see fig 4.
- Caution** two person lift required flex the bumper bar skin out at the sides then pull rearward to detach bumper bar skin from the vehicle some force may be required.
- Store bumper bar skin on suitable stands so not to damage.
- Remove the rear impact beam via removing the 6 M8 bolts then discard the impact beam and the bolts see fig 5.



Remove 3 x screws from inside each wheel arch

Fig 1



Remove 2 x plastic trim plugs from under side of the bumper bar skin.

Fig 2



Remove plastic cover from each side of boot cavity.

Fig 3



Remove bolt each side of the vehicle.

Fig 4



Remove impact beam via 3 x bolts each side then discard beam &

Fig 5

12. Fitment of tow bar to the vehicle via

- Offer towbar to rear panel of the vehicle so that the holes in the side plates align with the captive nuts where the impact beam was located.
- Then fasten loosely with M8 bolts flat & spring washers provided see assembly diagram for correct orientation of all components.
- Fit loose plate & M12 spring washer & nut to shipping hook mount.
- Fasten all hardware to torque listing.

13. Bumper bar skin cut

- Place masking tape on the outside of the bumper bar skin centrally so that the area can be marked out for bumper cut.
- Mark out as shown in fig 6.
- Then cut out section with small hacksaw or similar device.
- Ensure that all burrs & swarf are filed cleanly.
- Refit the bumper bar in the reverse of steps 11f through to 11 a.
- Fit the tongue part number 7341 with the two M 16 bolts & spring washers provided.

INSTALLATION INSTRUCTIONS

2479-TO SUIT HONDA ACCORD 02-2008-ON

ENSURE INSTRUCTIONS ARE UNDERSTOOD BEFORE INSTALLATION.

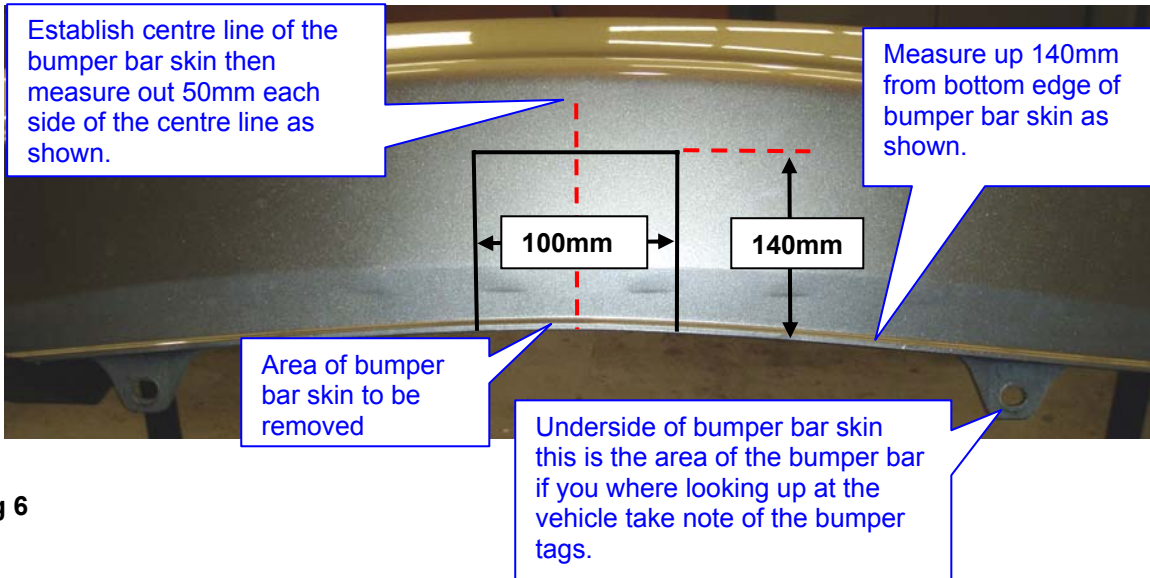

Fig 6

